



D2111
RESIDENTIAL

Digital Thermostat

Optional accessories
available, including Wi-Fi



Owner's
Manual
and
Installation
Instructions



CAUTION

Follow the Installation Instructions before proceeding. Set the thermostat mode to “OFF” prior to changing settings in setup or restoring Factory Defaults.

FCC Compliance Statement

This equipment has been tested and found to comply with the limits for an intentional radiator, pursuant to Part 15, subpart C of the FCC rules. These limits are designed to provide reasonable protection against harmful interference in a residential installation. This equipment generates, uses and can radiate radio frequency energy and, if not installed and used in accordance with the instructions, may cause harmful interference in radio communications. However, there is no guarantee that the interference will not occur in a particular installation. If this equipment does cause harmful interference to radio or television reception, which can be determined by turning the equipment off and on, the user is encouraged to try to correct the interference by one or more of the following measures:

- Reorient or relocate the receiving antenna.
- Increase the separation between the equipment and receiver.
- Connect the equipment into an outlet on a circuit different from that of the receiver.
- Consult the dealer or an experienced radio or TV technician for help.

Notice: Only peripherals complying with FCC limits may be attached to this equipment. Operation with noncompliant peripherals or peripherals not recommended by Venstar, is likely to result in interference to radio and TV reception. Changes or modifications to the product, not expressly approved by Venstar could void the user's authority to operate the equipment.

FCC - INDOOR Mobile Radio Information:

To comply with FCC/IC RF exposure limits for general population / uncontrolled exposure, the antenna(s) used for this transmitter must be installed to provide a separation distance of at least 20 cm from all persons and must not be co-located or operating in conjunction with any other antenna or transmitter.

This Device complies with Industry Canada License-exempt RSS standard(s). Operation is subject to the following two conditions: 1) this device may not cause interference, and 2) this device must accept any interference, including interference that may cause undesired operation of the device.

Under Industry Canada regulations, this radio transmitter may only operate using an antenna of a type and maximum (or lesser) gain approved for the transmitter by Industry Canada. To reduce potential radio interference to other users, the antenna type and its gain should be so chosen that the equivalent isotropically radiated power (e.i.r.p.) is not more than that necessary for successful communication.

Cet appareil est conforme avec Industrie Canada, exempts de licence standard RSS(s). Son fonctionnement est soumis aux deux conditions suivantes: 1) ce dispositif ne doit pas causer d'interférences, et 2) ce dispositif doit accepter toute interférence, y compris les interférences qui peuvent causer un mauvais fonctionnement de l'appareil.

En vertu des règlements d'Industrie Canada, cet émetteur de radio ne peut fonctionner en utilisant une antenne d'un type et maximale (ou moins) Gain approuvé pour l'émetteur par Industrie Canada. Pour réduire les interférences radio potentielles aux autres utilisateurs, le type d'antenne et son gain doivent être choisis afin que la puissance isotrope rayonnée équivalente (PIRE) ne est pas plus de ce qui est nécessaire pour une communication réussie.

We, Venstar, declare under our sole responsibility that the device to which this declaration relates: Complies with Part 15 of the FCC Rules. Operation is subject to the following two conditions: (1) this device may not cause harmful interference, and (2) this device must accept any interference received, including interference that may cause undesired operation.

FCC ID: MUH-SKYPORT4

IC: 12547A-SKYPORT4

This thermostat has the ability to receive updates to its firmware. Periodically firmware updates are released by the manufacturer to add features and/or performance enhancements. This manual was produced reflecting the most current firmware/feature set at the time of publication, firmware rev. 1.0. Firmware releases after rev. 1.0 may not be adequately depicted in this manual. Please refer to the appropriate website or contact your place of purchase to learn about changes to the thermostat after firmware release 1.0.



Glossary of Terms

Auto-Changeover: A mode in which the thermostat will turn on the heating or cooling based on room temperature demand.

Cool Setpoint: The warmest temperature that the space should rise to before cooling is turned on (without regard to deadband).

Deadband: The number of degrees the thermostat will wait, once a setpoint has been reached, before energizing heating or cooling.

Differential: The forced temperature difference between the heat setpoint and the cool setpoint.

Heat Setpoint: The coolest temperature that the space should drop to before heating is turned on (without regard to deadband).

Icon: The word or symbol that appears on the thermostat display.

Mode: The current operating condition of the thermostat (i.e. Off, Heat, Cool, Auto, Program On).

Non-Programmable Thermostat: A thermostat that does not have the capability of running Time Period Programming.

Programmable Thermostat: A thermostat that has the capability of running Time Period Programming.

Temperature Swing: Same as Deadband.

Time Period Programming: A program that allows the thermostat to automatically adjust the *heat setpoint* and/or the *cool setpoint* based on the time of the day.

Table of Contents

GET TO KNOW YOUR THERMOSTAT

Get to Know Your Thermostat.....	1
Quick Start	6

INSTALLATION INSTRUCTIONS

Installation Instructions	8
The Thermostat Backplate	10
Sample Wiring Diagrams.....	12
Test Operation.....	15

USER SETUP

Backlight Operation.....	16
Scrolling Display Options	17
Programming Vacation/Away.....	18
Emergency Heat	18
Wireless Module	19
Service Filter	21
Runtimes	22
Time Period Programming	23

INSTALLER SETUP

Program Mode Operation.....	25
Timers and Deadbands	26
Dry Contact Operation	27
Skyport.....	27
Local API.....	27
Factory Defaults.....	28
ADR	29
Locking/Unlocking the Keypad.....	35

TECHNICIAN SETUP

Equipment Testing	36
Advanced Output Testing.....	36
Advanced Setup Table	37
Troubleshooting	39

INDEX	40
-------------	----

WARRANTY	44
----------------	----

Get To Know Your Thermostat

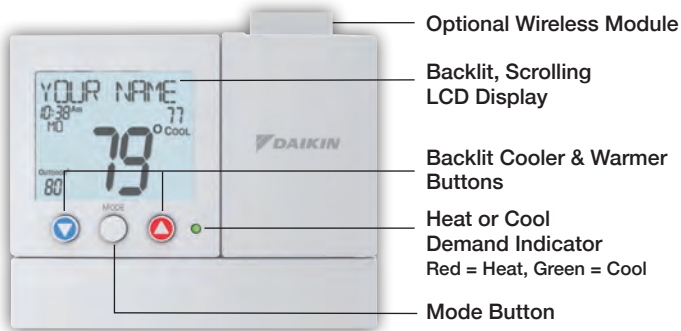

Setup Buttons Behind Door

Get To Know Your Thermostat



Setup Buttons

Get To Know Your Thermostat

Display Features

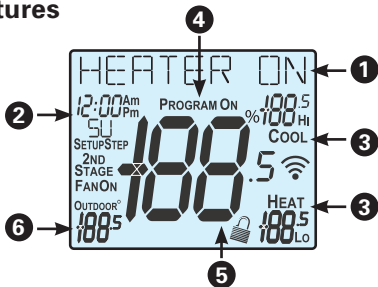

- 1** The scrolling display will be used to help you easily navigate the setup screens in the thermostat.
- 2** Clock with Day of the Week
Indicates the current time and day. This clock is also used to program the time period schedules.
- 3** Mode Indicators
Selects the operational mode of the equipment.
HEAT - Indicates the heating mode.
COOL - Indicates the air conditioning mode.
HEAT & COOL - Indicates the system will automatically change-over between heat and cool modes as the temperature varies.
OFF - Indicates heating and cooling is turned off.
- 4** Program icon
Indicates that Time Period Programming is running or is enabled to be set.
- 5** Room Temperature Display
Indicates the current room temperature and displays the outdoor temperature when selected.
- 6** Outdoor icon
Indicates the temperature displayed is from the optional outdoor sensor.

Get To Know Your Thermostat

Display Features

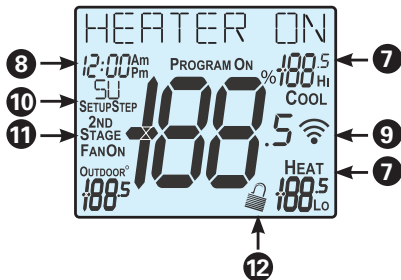

- 7** Desired Set Temperature
Indicates desired room temperature(s). Also displays the highest and lowest temperatures for the day.
- 8** Morning, Day, Evening & Night icons
Indicates the day part of the time period program.
- 9** Wi-Fi icons
Indicates the thermostat is currently connected to the Local Area Network, via the optional Wi-Fi module.
- 10** Setup Step icon
Indicates the step number when the thermostat is in the setup mode.
- 11** 2nd Stage icons
Indicates what stage of cooling or heating is currently energized.
- 12**  icon
Indicates the keypad has been locked.

Get To Know Your Thermostat

Display Features

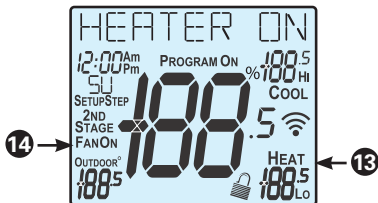

13 AuxHeat icon

Indicates 2nd stage electric strip heat is being used when the thermostat is programmed for Heat Pump operation.

14 Fan On icon

Indicates constant, continuous fan operation.
When **Fan On** is not lit - indicates the fan will only operate when necessary to heat or to cool.

Quick Start

During Setup and Programming

Press the **WARMER** or **COOLER** buttons to modify the selection.

Press the **MODE** button to advance and confirm through the setup steps.

Setting the Clock and Day*

**Not available when wi-fi module is present.*

Press the **SET CLOCK** button. Adjust the clock using the **WARMER** or **COOLER** buttons. Press **MODE** to advance to the day setting. Adjust the day using the **WARMER** or **COOLER** buttons. Press the **SET CLOCK** button to confirm settings.

TIP: To adjust the time by hours press and hold the **FAN** button while pressing the **WARMER** or **COOLER** buttons.



Selecting the Heat or Cool Mode

Select mode by pressing the **MODE** button.

Heating Only - Only the heating operation will be controlled by the thermostat in this mode.

Cooling Only - Only the cooling operation will be controlled by the thermostat in this mode.

Heating or Cooling (Auto-Changeover) - AUTO will automatically select heat or cool based on room temperature demand.

OFF - OFF indicates both heating and air conditioning systems are turned off.



Quick Start

Selecting your desired temperature

AUTO-CHANGEVER MODE - Pressing the WARMER or COOLER buttons in Auto mode will adjust both the heat and cool setpoints simultaneously. To adjust heat and cool setpoints individually, choose HEAT mode to adjust the heat setpoint and COOL mode to adjust the cool setpoint, then return to AUTO mode.

HEAT OR COOL MODE - Pressing the WARMER or COOLER buttons in Heat or Cool mode will adjust only the heat or cool setpoints individually displayed.

Using the Fan Button

Fan On indicates constant fan operation. You may turn the fan on even if the thermostat is in the OFF mode. Pressing the FAN button toggles this feature on or off. If you don't see "Fan On", the fan is in auto mode and will only turn on during a heat or cool demand.

FAN
ON|AUTO



Viewing the Temperature Sensors

OUTDOOR TEMP - Press the OUTDOOR button to view a connected outdoor wired sensor.

OUTDOOR



If the thermostat is connected to Skyport; upon pressing the OUTDOOR button the scrolling display will read "Forecast".

The forecasted high and low temperatures for the day will be displayed.

Press the OUTDOOR button again to view any connected outdoor wired sensor. (Remote or supply).

Note: If no outdoor sensor is connected, and there isn't outdoor temperature via Wi-Fi, then 2 dashes [- -] will appear with the first button press.

REMOTE/SUPPLY TEMP - Press the **Accessory Status** button to view linked wireless wired sensors and other accessories. Press the **Accessory Status** button to return to the main screen.

ACCESSORY
STATUS



Installation Instructions

Remove and Replace the old thermostat

To install the thermostat properly, please follow these step by step instructions. If you are unsure about any of these steps, call a qualified technician for assistance.

- Assemble tools: Flat blade screwdriver, wire cutters and wire strippers.



- Make sure your Heater/Air Conditioner is working properly before beginning installation of the thermostat.
- Carefully unpack the thermostat. Save the screws, any brackets, and instructions.
- Turn off the power to the Heating/Air Conditioning system at the main fuse panel. Most residential systems have a separate breaker for disconnecting power to the furnace.
- Remove the cover of the old thermostat. If it does not come off easily, check for screws.
- Loosen the screws holding the thermostat base or subbase to the wall and lift away.
- If you have a smart phone handy, take a photo of the wiring for future reference.
- Disconnect the wires from the old thermostat. Tape the ends of the wires as you disconnect them, and mark them with the letter of the terminal for easy reconnection to the new thermostat.
- Keep the old thermostat for reference purposes, until your new thermostat is functioning properly.

Installation Instructions

Wire Connections

If the terminal designations on your old thermostat do not match those on the new thermostat, **refer to the chart below or the wiring diagrams that follow.**

Wire from the old thermostat terminal marked	Function	Install on the new thermostat connector marked
G or F	Fan	G
Y1, Y	Cooling	Y1
W1, W	Heating	W1/O/B
Rh, R, M, Vr, A	Power	R
C	Common	C
O/B	Rev. Valve	W1/O/B*
W2	2nd Stage Heat	W2
Ck1	Dry Contact Switch	DRY CONTACT
CKGND	Dry Contact Switch	DRY CONTACT

* O/B is used if your system is a Heat Pump.

Installation Instructions

The Thermostat Backplate

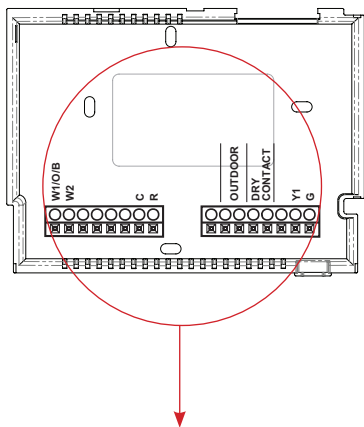

To remove the thermostat backplate: Gently separate the display from the base by pulling first from one side, then the other until the two pieces unsnap. A small screwdriver may be used, very carefully, to start separating the two pieces.

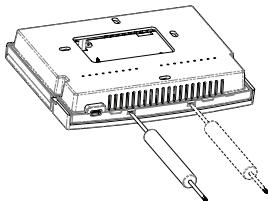

R	24 VAC return	C	24 VAC common
G	Fan relay	OUTDOOR SENSOR	Outdoor sensor connections
W1/O/B	1st stage heat circuit	DRY CONTACT	Dry Contact connections
W2	2nd stage heat circuit		
Y1	1st stage compressor relay		

IMPORTANT: This thermostat requires both **R** (24 VAC Return) and **C** (24 VAC Common) be connected to the backplate terminals.

Installation Instructions

Check Dip Switch

Ensure which switch is correct for your system. Dip switches are located on the back of the thermostat.

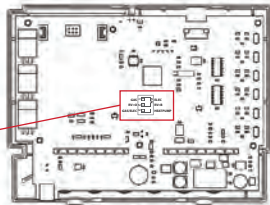
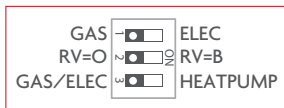

OR

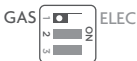

1. When GAS/EL or HP is set for GAS/EL:
This switch (GAS or ELEC) controls how the thermostat will control the Fan (G) terminal in heating mode. When GAS is chosen, the thermostat will not energize the Fan (G) terminal in heating. When ELEC is chosen the thermostat will energize the fan in heating.

2. When GAS/EL or HP is set for HP:
This switch (GAS or ELEC) defines the Aux Heat type. When GAS is chosen, the auxiliary heat will not be allowed to run during heat pump operation. When ELEC is chosen, up to two stages of auxiliary strip heat will be allowed to run.



OR



For Heat Pump Only
When the GAS/EL or HP dip switch is configured for HP, this dip switch (O or B) must be set to control the appropriate reversing valve. If O is chosen, the W1/O/B terminal will energize in cooling. If B is chosen, the W1/O/B terminal will energize in heating.



OR



This dip switch configures the thermostat to control a conventional gas/electric system or a heat pump. If your system is anything other than a heat pump, leave this switch set for GAS/EL.

Installation Instructions

Sample Wiring Diagrams

Conventional Heating and Cooling Systems

3 Wire, Heat Only

Residential & Commercial 1 Stage Heating with no Fan.

R 24VAC Power
C 24VAC Common
W1/O/B 1st Stage Heat

J1 = Gas/Elec
J2 = O (not used)
J3 = Gas

4 Wire, Cool Only

Residential & Commercial 1 Stage Cooling.

R 24VAC Power
C 24VAC Common
Y1 1st Stage Cool
G Fan

J1 = Gas/Elec
J2 = O (not used)
J3 = Gas

5 Wire, 1 Stage Cooling, 1 Stage Heat

Residential & Commercial 1 Stage Cooling, with 1 stage Gas Heat.

R 24VAC Power
C 24VAC Common
W1/O/B 1st Stage Heat
Y1 1st Stage Cool
G Fan

J1 = Gas/Elec
J2 = O (not used)
J3 = Gas

5 Wire, 1 Stage Cooling, 1 Stage Heat

Residential & Commercial 1 Stage Cooling, with 1 stage Electric Heat.

R 24VAC Power
C 24VAC Common
W1/O/B 1st Stage Heat
Y1 1st Stage Cool
G Fan

J1 = Gas/Elec
J2 = O (not used)
J3 = Electric

Installation Instructions

Sample Wiring Diagrams

Heat Pump Systems

5 Wire, 1 Stage Cooling, 1 Stage Heat

Residential & Commercial Heat Pump with
'O' Reversing Valve

R	24VAC Power
C	24VAC Common
W1/O/B	Reversing Valve
Y1	1st Stage Compressor (Cool or Heat)
G	Fan
J1	= Heat Pump
J2	= O
J3	= Gas

6 Wire, 1 Stage Cooling, 2 Stage Heat

Residential & Commercial Heat Pump with
'O' Reversing Valve

R	24VAC Power
C	24VAC Common
W1/O/B	Reversing Valve
Y1	1st Stage Compressor (Cool or Heat)
W2	Aux Heat
G	Fan
J1	= Heat Pump
J2	= O
J3	= Electric

Installation Instructions

Sample Wiring Diagrams

Dry Contact

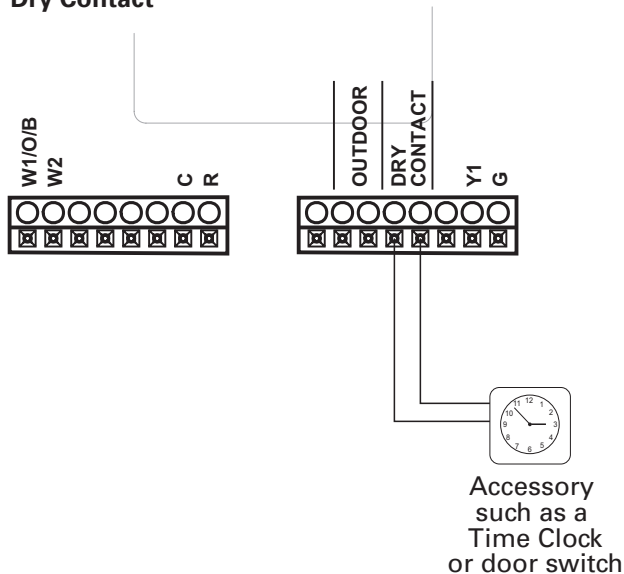

Installation Instructions Test Operation

The technician setup is a diagnostic feature that enables testing of all outputs.

To enter Technician Setup, press and hold the SETUP button for 10 seconds until all the icons appear. Follow the next steps to view settings and test equipment.

1. Press MODE to view the version numbers of the thermostat.
2. Press MODE again to view the jumper settings and current state of the Dry Contact terminals.

3. Press MODE again and the scrolling display will read "TURN ON EQUIPMENT?" Press WARMER for Yes or COOLER for No.

If Yes is chosen, press WARMER to turn on heat or COOLER to turn on Cooling. The scrolling display will read "NOTHING ON." Next:

Press WARMER to turn on and cycle up through the heating stages.
Press COOLER to turn the heating stages off. Press MODE to exit.

Press COOLER to turn on and cycle down through the cooling stages.
Press WARMER to turn the cooling stages off. Press MODE to exit.

4. Press MODE until "CALIBRATE SENSORS?" appears on the scrolling display. Press WARMER for Yes or COOLER for No. Press MODE to select which sensor to calibrate. Use WARMER or COOLER to modify your selection.

To exit Technician Setup at any time, press the SETUP button. Technician Setup will automatically exit after 10 minutes if no buttons are pressed.

User Setup: Backlight Operation

How to Change Settings in the Setup Screens

To enter Advanced Setup, press the **SETUP** button, then press **MODE**. Use the **WARMER** or **COOLER** buttons to adjust the value of your selection. Press **MODE** to advance to the next setup step. Press **SETUP** again to leave the setup screens.



Backlight (Setup Steps 3-8)

Backlight (setup step 3)

Off - Backlight turns on with any button press and turns off after 8 seconds.

On - Backlight is on continuously.

Backlight Intensity Level (setup step 4)

The backlight can be adjusted between Off and seven levels of brightness.

Night Dimmer (setup step 5) - Selecting **On** allows for automatic dimming of the display at night.

Night Dimmer Brightness (setup step 6)

Off through seven levels of brightness

Night Dimmer Start Time (setup step 7) - 12:00 am to 12:00 am

Night Dimmer Stop Time (setup step 8) - 12:00 am to 12:00 am

Language (Setup Step 15)

Setup step instructions on the scrolling display can be set for English, Spanish, or French.

Press the SETUP button, then press MODE repeatedly until the Language setup step appears. Use the WARMER or COOLER buttons to make selection. Press MODE to advance to the next step. Press SETUP to leave the setup screens.

User Setup: Scrolling Screen and Display Options

Scrolling Display Method (Setup Step 16)

This option allows the user to choose how the scrolling text is displayed. Options are:

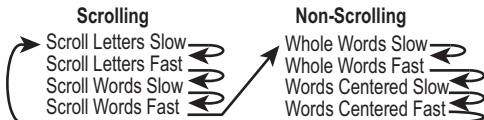

Press the **SETUP** button, then press **MODE** repeatedly until the Scrolling Method setup step appears. Use the **WARMER** or **COOLER** buttons to make selection. Press **MODE** to advance to the next step. Press **SETUP** to leave the setup screens.



Example of “Whole Words Centered”:

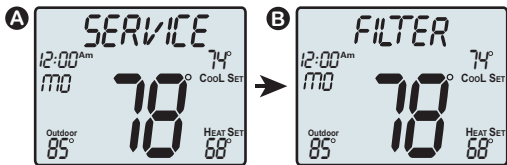

User Setup

Vacation & Away Settings

The Vacation feature allows the thermostat to use temporary, energy saving setpoints without having to change regular programming.



The HOME/AWAY feature allows for a one button press to bring in your stored unoccupied vacation settings. A subsequent press of the HOME/AWAY button restores the last used comfort settings.



Press the VACATION button to enter Vacation/Away programming. Use the WARMER and COOLER buttons to choose the number of days desired to run the in Vacation/Away settings.

To confirm your settings and advance to the next step, press the MODE button again. Choose the desired Vacation/Away Mode. Press the MODE again to adjust the 'unoccupied' setpoint. If you selected auto changeover mode for unoccupied/vacation settings, then pressing MODE again will allow the adjusting of the 2nd setpoint. Otherwise press MODE to confirm and return to normal operation.

Press the VACATION button again to return to the main screen. Both VACATION and AWAY use these same settings. VACATION button use specifies a duration of days for these settings, whereas Away maintains these settings until the HOME/AWAY button is pressed again.

When the VACATION button is pressed and the thermostat detects that a Wi-Fi module is installed:

During Non-Vacation Periods: the scrolling display will read:
"Use Skyport to View/Edit Settings"

During Vacation Period: the scrolling display will read:
"To cancel VACATION press MODE button"

NOTE: If the HOME/AWAY button is pressed during an active VACATION period, the scrolling display will read: "To cancel VACATION press MODE button."

The thermostat must be running in Program On for VACATION to have any effect. After you alter any settings, they will take effect until midnight on that day. The thermostat does not need to be running in Program On for the HOME/AWAY button to have effect.

Emergency Heat

The Emergency Heat function is only available if your thermostat is set to control a Heat Pump.



To initiate the Emergency Heat feature, Press the EMERGENCY button. During Emergency Heat operation the thermostat will turn on the fan and auxiliary stages of heat when there is a demand for heat. The compressor used for heating and all stages of cooling will be unavailable. To exit Emergency Heat, press the EMERGENCY button.

User Setup - Wireless Modules

Wireless Module

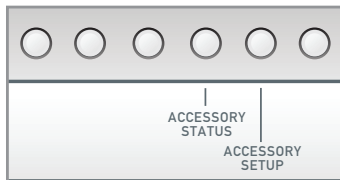

The **Accessory Status** button allows the user to view the status of wired and wireless accessories. For many of the wireless devices this status includes: Battery Level, Signal Strength & LastTime Updated.

If there is an optional wireless module installed, the **Accessory Setup** button allows the user to link or connect wireless devices to the thermostat, or the thermostat to the network.

User Setup - Wireless Modules

Wi-Fi Module

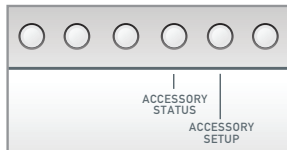

Wireless Module

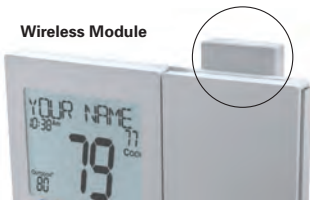

Please follow the instructions included with the Wi-Fi module to connect to an Access Point or view status. The general instructions are below.

Wi-Fi Module

If the  is present on the display then the thermostat is connected to the Wi-Fi Access Point. If just the “dot” of this icon appears, then just the Wi-Fi module is recognized.

Press the **Accessory Status** button, then press either the Cooler button to view connected Wi-Fi sensors, OR press the Warmer button to view the Wi-Fi status and settings.

Press the Mode button to step through the connected sensors or the Wi-Fi status screens listed below.

- Wi-Fi status (connecting, connected, etc.)
- Signal strength
- Access point name
- IP address
- MAC address
- Skyport status (connecting, connected, etc.)
- Local API status (Enabled, Disabled)
- Module version

• At any time press the **Accessory Status** button to leave the status screens.

Press the Accessory Setup button to enter Wi-Fi or Skyport setup:

Press the Cooler button to configure Wi-Fi settings.

Press the Warmer button to join this thermostat to a Skyport account. If the thermostat is connected to Wi-Fi and the Internet, a Device ID will appear on the scrolling display of the thermostat. You will enter this code to add this thermostat to your Skyport account via a browser or the Skyport mobile app.

Note: To connect to Skyport Cloud Services, Setup Step #27 must be set to on.

User Setup - Service Filter

These setup steps allow the user to monitor equipment runtimes and program service alerts. Service alerts are displayed in the scrolling marquee.



Press and hold FAN to clear service alert messages from the scrolling marquee.

Runtime hours or days appear in the clock display.



Service Filter Runtime (Setup Steps 9-10, 12-13)

Current Service Filter Runtime Hours (Setup Step 9) - This counter keeps track of the number of hours of fan runtime in the Heating mode, Cooling mode, and in stand alone Fan operation. Press FAN to reset.

Current Service Filter Calendar Days (Setup Step 10) - This counter displays the total number of calendar days that have elapsed since the counter was reset to help the user track Fan runtime. Press FAN to reset.

Set Service Filter Runtime Hours (Setup Step 12) - This timer allows the user to specify the number of hours the fan will run before the "Replace Filter" alert will be displayed. Press COOLER continuously until OFF is displayed to disable this alert.

Set Service Filter Calendar Days (Setup Step 13) - This timer allows the user to specify the number of calendar days that will elapse before the "Replace Filter" alert will be displayed. Press COOLER continuously until OFF is displayed to disable this feature.

Press the SETUP button, then press MODE repeatedly until the desired setup step appears. Use the WARMER or COOLER buttons to make selection. Press MODE to advance to the next step. Press SETUP to leave the setup screens.



User Setup - Runtimes

*To view, set, or reset System Runtimes, press the **SETUP** button, then press **MODE**. Press **MODE** to advance to the desired setup step. Use the **WARMER** or **COOLER** buttons to adjust the value of your selection. Press **SETUP** again to leave the setup screens.*

UV Lamp Runtime (setup steps 11, 14)

Current UV Lamp Calendar Days (Setup Step 11) - This counter displays the total number of calendar days that have elapsed to help the user track UV lamp runtime. Press **FAN** to reset.

Set UV Lamp Calendar Days (Setup Step 14) - This timer allows the user to specify the number of calendar days the UV Lamp will operate before the "Replace UV Lamp" alert will be displayed. Press **COOLER** continuously until **OFF** appears to disable this alert.

User Setup - Time Period Programming

Programming a Daily Schedule*

**not available when wi-fi module is present*

To enter Time Period Programming screens, Press and hold PROGRAM until the scrolling prompt appears.

OFF -Time Period Program is off.

RUN -Time Period Program is running.

HOLD TO SET - Press and hold PROGRAM to make Time Period Programming changes.

Select Day of Week to program - Press the WARMER or COOLER buttons to choose the day of the week to be Press MODE to advance to the next step.

Program Button



(continued next page)

User Setup - Time Period Programming

This thermostat features four programmable time periods per 24 hour day: Morning, Day, Evening, and Night. The start time for each time period is adjustable. The stop time for each time period is the start time for the next period. Each time period, or day part may be individually disabled.

Select the Day to Program - Press the WARMER or COOLER to select the desired Day or Week Part in the case of 5-2 (weekday – weekend) programming.

Enable/Disable Morning Period - Press the WARMER or COOLER to select ON or OFF. If the default ON is selected, then the Morning period will run complete with the Mode and Set Points selected. If OFF is selected then the Morning day part will be skipped and the thermostat will use the next day part that is enabled.

Select Morning Mode - Press the WARMER or COOLER to select the desired mode, which includes OFF. You may be limited by the available modes in advanced Installer setup step#2. Press MODE to advance to the next step.

Select Morning Start Time - Press the WARMER or COOLER buttons to adjust the time of day desired. Press MODE to advance to the next step.

Select Morning Cool Setpoint - Press the WARMER or COOLER buttons to adjust the cool setpoint desired. This step will appear if Cool or Auto Mode was selected in the step where the Morning mode is specified. Press MODE to advance to the next step.

Select Morning Heat Setpoint - Press the WARMER or COOLER buttons to adjust the heat setpoint desired. This step will appear if Heat or Auto Mode was selected in the step where the Morning mode is specified. Press MODE to advance to the next step.

Repeat Enable, Mode, Start Time and Setpoint programming for Day, Evening, and Night.

“Copy Current Day to Next Day” is available - Press the UP button to Copy the current day's program to the next day. Press Mode again to continue copying the following day.

Press the PROGRAM Button to exit Time Period Programming at any time.

Installer Setup

How to Change Settings in the Setup Screens

*To enter Advanced Setup, press the **SETUP** button, then press **MODE**. Use the **WARMER** or **COOLER** buttons to adjust the value of your selection. Press **MODE** to advance to the next setup step. Press **SETUP** again to leave the setup screens.*



Selecting Your Time Period Schedule (setup step 1)

This thermostat may be configured to be programmable or non programmable.

7 Day Program - Allows all seven days to be programmed independently.

Non Program - No advanced time period programming available.

1 Day Program - Allows one 24 hour day to be programmed. This same schedule will be repeated everyday the program is set to run.

5/2 Day Program - Allows weekdays, Saturday, and Sunday to be programmed independently.

Selecting Your Available Modes (setup step 2)

Auto-Changeover - Allows the thermostat to turn on heating or cooling based on room temperature demand. Also allows the manual selection of HEAT only or COOL only and OFF.

Heat and Cool - Allows the thermostat to turn on heating or cooling depending on which one has been manually selected. Auto-Changeover is not available when this is selected.

Heat Only - Allows the thermostat to only turn on HEAT or OFF modes.

Cool Only - Allows the thermostat to only turn on COOL or OFF modes.

Installer Setup

Cycles Per Hour (setup step 17)

The Cycles Per Hour setting may limit the number of times per hour your HVAC unit may energize. For example, at a setting of 6 cycles per hour the HVAC unit will only be allowed to energize once every 10 minutes. The Cycles Per Hour limit may be overridden and reset by pressing the WARMER or COOLER buttons on the thermostat. Settings are No Limit, 2, 3, 4, 5, or 6.

Compressor Minimum Off Minutes (setup step 18)

This feature allows the user to set a minimum off time for the compressor. Settings are 5 mins., 3 mins., or 0 mins.

Minimum Heat/Cool Setpoint Difference (setup step 19)

This feature allows the user to set the minimum gap between Heat and Cool setpoints in **AUTO** mode. Select from 0 to 6. If setup step 2 is not set for **AUTO-CHANGEOVER**, this step will not appear.

Number of Heat Stages (setup step 20)

This setting assures proper stage callouts on the thermostat display for non-heat pump applications.

Number of Cool Stages (setup step 21)

This setting assures proper stage callouts on the thermostat display for non-heat pump applications.

Number of Aux Stages (setup step 22)

This feature is for heat pump application only.

This feature allows for proper Aux Heat Staging. (0-2 stages)

Deadband Settings (setup step 23)

The Deadband is the number of degrees or minutes that the thermostat waits before it initiates the stages of heating or cooling.

1st Stage Deadband (Setup Step 23) - Specifies the minimum temperature difference between the room temperature and the desired setpoint before the first stage of heating or cooling is allowed to turn on. (1 - 6 degrees) For example, if the heat setpoint is 68° and the 1st Stage deadband is set to 2 degrees, the room temperature will need to reach 66° before the heat turns on.

Fahrenheit or Celsius (setup step 24)

This feature allows the thermostat to display temperature in Fahrenheit or Celsius.

Press Fan To Clear All Messages (setup step 37)

This feature allows the user to clear all current error messages from the display.

Installer Setup

Dry Contact Operation (Setup Step 25 - 26)

Dry Contact Polarity (setup step 25)

Open (Normally Open) - The dry contact is open until the connected device closes the circuit.



'Idle'



'Active'

Closed (Normally Closed) - The dry contact is closed until the connected device opens the circuit.



'Idle'



'Active'

Dry Contact Use (setup step 26)

CONDENSATE - If selected when the dry contact is active, the thermostat will lockout the compressor terminal(s) and "CONDENSATE PAN OVERFLOW" will appear on the display.

VACATION - If VACATION is selected when the dry contact is active, the thermostat will be forced into AWAY/unoccupied settings.

FDD - If FDD is selected when the dry contact is active, the scrolling display will read "Equipment fault". This error message will disappear when the Dry Contact is idle.

Skyport (setup step 27)

Set to ON to allow access to Skyport services or to OFF to not allow access to Skyport services.

Local API (setup step 28)

Set to ON to allow 3rd party software to interface with your thermostat such as home automation software.

Installer Setup

Resetting the Thermostat to the Factory Default Settings

(for default values see page 39, Advanced SetupTable)

If, for any reason, you desire to return all the stored settings back to the factory default settings, follow the instructions below.

WARNING: This will reset all Time Period and Advanced Programming to the default settings. Any information entered prior to this reset may be permanently lost.

- 1 Press and hold SETUP for 10 seconds. All icons will appear on the display.

Keep pressing the **SETUP** button until you see this screen.

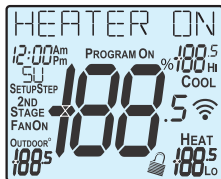

- 2 After all the icons appear, release SETUP. Press and hold FAN for 5 seconds. DEFAULTS will appear on the display.

Keep pressing the **FAN** button until you see this screen.



- 3 After DEFAULTS appears, release FAN. Press MODE to return to normal operation.



Overview

Daikin Digital thermostats support the handling of specific signals from the utility provider. The utility generated signals carry pricing information and/or setback actions that alter the comfort settings of the thermostat in order to reduce energy usage on demand. This is known as Automated Demand Response or ADR for short. You must register to participate in a utility sponsored program, if offered by your local utility, to take advantage of this feature.

Skyport Cloud Services

From the web application the user will select Thermostat Settings from the left column. Then the Demand Response button is selected.

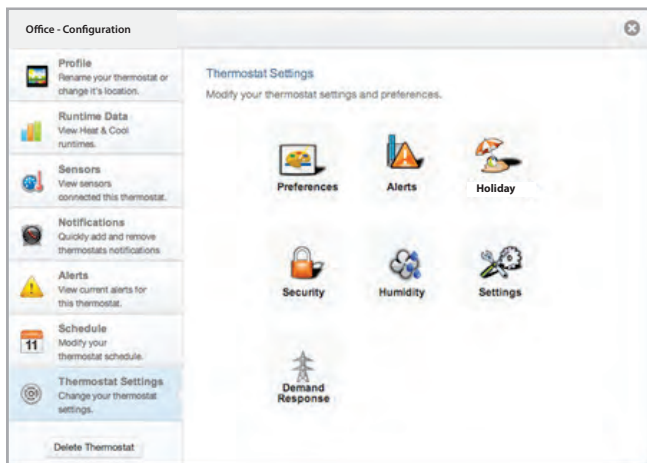

Installer Setup - Automated Demand Response

The Demand Response configuration page, shown below, is where the thermostat is configured to respond to the energy provider's signals. It also sets operational parameters for the thermostat.

The left column of the ADR configuration page allows or prevents access by the utility. Here communication with the utility and your thermostat may be turned On or Off.

The selected utility will provide a Program ID.

The Account ID would normally be the occupants utility account number.

The screenshot shows a thermostat configuration window titled "Automated Demand Response" with two tabs: "Configuration" (selected) and "Overview". On the left is a sidebar menu for "Office - Configuration" with options: Profile, Runtime Data, Sensors, Notifications, Alerts, Schedule, and Thermostat Settings. The main configuration area features a "Demand Response" toggle set to "ON" and a "What is Demand Response?" link. Below this are fields for "Select Utility" (LADWP), "Program Id." (test-program), and "Account Id." (1234). The right side contains several setting sections: "Min & Max Settings" (Event Max Cool Setpoint: 65°F, Event Min Heat Setpoint: 65°F), "Static Settings" (Static Cool Setpoint: 78°F, Static Heat Setpoint: 65°F), "Offset Settings" (Cool Setpoint Offset: +2, Heat Setpoint Offset: -2), and "Price Settings" (Price Trigger: 45, Price Dependent Action: Observe Setpoint Offsets). At the bottom are "Cancel" and "Save" buttons.

Installer Setup - Automated Demand Response

The right column of the ADR configuration page is where the occupant adjusts the operational parameters for ADR. The utility may send up to 3 types of ADR signals to Skyport. These are:

1) Pricing for the cost of energy, **2) An Offset** to the occupants' comfort setpoints, and **3) a signal** to enforce discrete or Static setpoints.

The Maximum Cooling Setpoint and Minimum Heating Setpoints for ADR events are adjusted here.

The Static Settings are applied when the utility sends a signal to allow the occupant to enforce their own discrete temperature settings during an ADR event.

The Offset Settings allow the utility to modify the Cool or Heat setpoints by the value set here during an ADR event.

A Price Trigger setting allows the occupant to set the maximum cost of energy threshold. When this threshold is exceeded the Price dependent action is enforced. This Price Trigger and Dependent action is enforced independent of an ADR event, as long as the utility sends 'real-time' pricing.

Office - Configuration

Profile
Rename your thermostat or change it's location.

Runtime Data
View Heat & Cool runtimes.

Sensors
View sensors connected to this thermostat.

Notifications
Quickly add and remove thermostat notifications

Alerts
View current alerts for this thermostat.

Schedule
Modify your thermostat schedule.

Thermostat Settings
Change your thermostat settings.

Delete Thermostat

Automated Demand Response

Configuration Overview

Demand Response
ON OFF
[What is Demand Response?](#)

Select Utility: LADWP

Program Id: test-program

Account Id: 1234

Min & Max Settings

Event Max Cool Setpoint: 85° F

Event Min Heat Setpoint: 65° F

Static Settings

Static Cool Setpoint: 78° F

Static Heat Setpoint: 65° F

Offset Settings

Cool Setpoint Offset: +2

Heat Setpoint Offset: -2

Price Settings

Price Trigger: 65

Price Dependent Action

Observe Setpoint Offsets

Cancel Save

Installer Setup - Automated Demand Response

Selecting the Overview tab of the ADR page will cause a summary of ADR events to be displayed.

Office - Configuration

- Profile**
Rename your thermostat or change its location.
- Runtime Data**
View Heat & Cool runtimes.
- Sensors**
View sensors connected this thermostat.
- Notifications**
Quickly add and remove thermostats notifications.
- Alerts**
View current alerts for this thermostat.
- Schedule**
Modify your thermostat schedule.
- Thermostat Settings**
Change your thermostat settings.

Delete Thermostat

Automated Demand Response

Configuration Overview

Event Id	Event Type	Status	Start Time	Stop Time
1233407844	Price	Success	08/10/2014 1:00pm	08/10/2014 2:00pm
1233407844	Price	Success	08/15/2014 4:00pm	08/15/2014 5:00pm

Cancel Save ✓

Security Humidity Settings

Demand Response

Installer Setup - Automated Demand Response

ADR (setup step 29)

Controls whether you want the thermostat to possibly respond to signals from the utility provider. Select ON to allow this and to have steps 30-36 appear.

Price Dependent Action (setup step 30)

Allows the user to determine what action is taken when the price rises above the set threshold. Note that the threshold price is only adjustable via Skyport.

None – take no action when the set price threshold is exceeded

Observe Setpoint Offsets – will offset the heat and cool setpoints by the amounts specified in setup steps 35 and 36

Observe Static Setpoints – will set the heat and cool setpoints to the values specified in setup steps 33 and 34

Event Max Cool Setpoint (setup step 31)

Event Min Heat Setpoint (setup step 32)

Specifies the range of allowable setpoint adjustments to be enforced when any ADR signal has been received from the utility. Since you might be paying more for energy while an event is active, you can impose tighter limits on setpoint ranges that are only enforced during the event.

Static Cool Setpoint (setup step 33)

Static Heat Setpoint (setup step 34)

Specifies the setpoints that will come into use during an event when the PRICE DEPENDENT ACTION is set to OBSERVE STATIC SETPOINTS

Cool Setpoint Offset (setup step 35)

Heat Setpoint Offset (setup step 36)

Specifies how much the current setpoints in effect prior to an event will be altered during an event when the PRICE DEPENDENT ACTION is set to OBSERVE SETPOINT OFFSETS. The heat setpoint can be automatically lowered by 1 to 10 degrees while the cool setpoint can be automatically raised by 1 to 10 degrees

DISPLAY INDICATIONS WHEN AN ADR EVENT IS HAPPENING

After setting your desired values for use during an ADR event, the scrolling display will give a little information when an event is pending or active. For instance, when an ADR event has been sent to your thermostat, you might see ADR STARTS at 4:15 to notify you of a pending event. Once active, you might see ADR STOPS at 5:30. If you have configured a threshold for cost of energy past which you want to trigger an event, you will see PRICING EVENT on the display. When an event is active, you can press any of COOLER, WARMER or MODE buttons, followed by the WARMER to opt out of the event.

Installer Setup

Locking/Unlocking the Keypad

To prevent unauthorized use of the thermostat, the front panel buttons may be disabled. To disable, or 'lock' the keypad, press and hold the MODE button. While holding the MODE button, press the WARMER and COOLER buttons together. The  icon will appear on the display, then release the buttons.

Press all three buttons in the order outlined above for keypad lockout

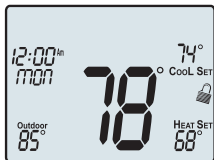

To **unlock** the keypad, press and hold the MODE button. While holding the MODE button, press the WARMER and COOLER buttons together. The  icon will disappear from the display, then release the buttons.

Technician Setup

To enter Technician Setup, press and hold the **SETUP** button for 5 seconds. After all the icons appear, press **MODE**. The version number of the thermostat will appear in the scrolling text. Press **MODE** to advance to the next step. Use the **WARMER** or **COOLER** buttons to adjust the value of your selection. To leave Technician Setup, press **SETUP**.

Hold for 5 seconds

All icons appear

Press **MODE** to advance through the setup steps

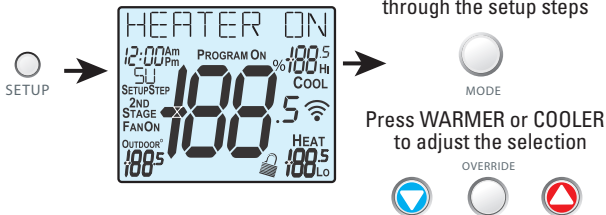

Technician Setup is for diagnostic and testing purposes and is intended for use by a qualified technician. See page 15 for more detailed instructions.

Technician Setup contains the following options:

- View the version number of the thermostat.
- View the jumper setting of **J1** (Gas/Electric or Heat Pump), **J2** (Reversing Valve: RV=O or RV=B), and **J3** (Fan: Gas or Electric) jumpers located on the back of the thermostat. (Remove thermostat from backplate for access)
- View the state of the Dry Contact and Fault terminals.
- Turn on equipment outputs for testing.
- Calibrate thermostat and remote sensors.

Advanced Setup Table

Df = Factory Default Setting

Step#	Description	Pg#	Range	Df
1	Prog Mode	25	Non, 1 Day, 5/2 Day, 7 Day	7
2	Available Modes	25	Heat/Cool/Auto/Off, Heat/Cool/Off, Heat/Off, Cool/Off	Heat/Cool/ Auto/Off
3	Backlight	16	On, Off	Off
4	Backlight Level	16	Off thru 7 levels of brightness	Level 5
5	Night Dimmer	16	On/Off	Off
6	Night Dimmer Brightness	16	Off thru 7 levels of brightness	2 (20%)
7	Night Dimmer StartTime	16	12A-12A	8:00P
8	Night Dimmer StopTime	16	12A-12A	6:00A
9	Current Service Filter Runtime Hours	21	0-1999 Hours	0
10	Current Service Filter Calendar Days	21	0-720 Days	0
11	Current UV Lamp Calendar Days	22	0-720 Days	0
12	Set Service Filter Runtime Hours	21	0-1950 hours	0
13	Set Service Filter Calendar Days	21	0-720 Days	0
14	Set UV Lamp Calendar Days	22	0-720 Days	0
15	Language	16	English, Espanol, Francais	English
16	Scrolling Method	17	"L-R Slow, L-R Fast, Word L-R Slow, Word L-R Fast, Whole Word L Slow, Whole Word R Slow, Whole Word Ctr. Fast, Whole Word Ctr. Slow	Whole Word Center Fast
17	Cycles Per Hour	26	No Limit, 2, 3, 4, 5, 6	6
18	Compressor Minimum Off Minutes	26	0, 3, 5 Minutes	5
19	Min. Heat/Cool Setpoint Difference	26	0 - 6 Degrees	2
20	Number of Heat Stages	26	0 - 2	2
21	Number of Cool Stages	26	0 - 1	1
22	Number of Aux Stages	26	0, 1	0
23	1st Stage Deadband	26	1 - 6 Degrees	2
24	F/C	26	Fahrenheit (F), Celsius (C)	F
25	Dry Contact Polarity	27	Open, Closed	Open
26	Dry Contact Use	27	Condensate, Vacation, FDD	Vacation
27	Skyport	27	On, Off	On
28	Local API	27	On, Off	Off
29	ADR	33	On, Off	Off

cont. next page

Advanced Setup Table

Df = Factory Default Setting

Step#	Description	Pg#	Range	Df
30	Price Dependent Action	33	None, Observe Setpoint Offset, Observe Static Setpoints	None
31	Event Max Cool Setpoint	33	65 - 85	85
32	Event Min Heat Setpoint	33	65 - 85	65
33	Static Cool Setpoint	33	65 - 85	78
34	Static Heat Setpoint	33	65 - 85	68
35	Cool Setpoint Offset	34	1 to 10	2
36	Heat Setpoint Offset	34	-1 to -10	-2
37	Press Fan To Clear All Messages	26		

Troubleshooting

- **SYMPTOM:** The air conditioning does not attempt to turn on.
CAUSE: The compressor timer lockout may prevent the air conditioner from turning on for a period of time.
REMEDY: Consult the Owner's Manual in the Installer Setup section to defeat the Cycles Per Hour (*page 28*).
- **SYMPTOM:** The display is blank.
CAUSE: Lack of proper power.
REMEDY: Make sure the power is on to the furnace and that you have 24vac between **R & C**.
- **SYMPTOM:** When controlling a residential heat pump, and asking for cooling, the heat comes on.
CAUSE: The thermostat reversing valve jumper is set for **"B"**.
REMEDY: Set the reversing valve jumper for **"O"**.
- **SYMPTOM:** When calling for cooling, both the heat and cool come on.
CAUSE: The thermostat equipment jumper is configured for **"HP"** and the HVAC unit is a Gas/Electric.
REMEDY: Set the equipment jumper for **"Gas"**.
- **SYMPTOM:** When the Program button is pressed, the display reads **"DISABLED"**.
CAUSE: Program mode is set to **"NON PROGRAM"**.
REMEDY: Set Program Mode (Setup 1) to **1, 5/2, or 7 Day**.
See Selecting Your Program Mode (page 21).

Index

A

Alerts

see Runtime

Accessory, 19

Setup 19

Auto

adjust temperature, 6
changeover, 3
fan, 7
mode, iii, 3, 7

AuxHeat icon, 5

B

b reversing valve, 10, 34

Backplate, 10

Buttons

accessory, 2
cooler (down) 1
emergency heat, 2, 18
fan, 1, 2, 7
front panel, 1, 2
mode, 1, 6
outdoor, 1, 8
program, 1, 25
set clock, 2, 6
setup, 16
vacation, 2, 18
up (warmer), 1, 7

C

C, 9, 10

Calibration, 15, 32

Celsius, 28

Clock

display, 3
setting, 6

Compressor Lockout, 18

Cool

1st stage deadband,
see Deadband
droop, *see Deadband*
electric/heat pump, 10
icon, 2
indicator, 1
mode, 2, 5
program, *see Program*
setpoint, 3, 6

Condensate Drain Pan, 29

Copy Function

see Program

Cycles Per Hour, 28

D

Day

icon, 3
programming, 6, 26, 27

Deadband

1st stage, 28

Differential

heat and cool, 28

Disabled Keypad

see Keypad Lockout

Dip Switches

ELEC, 11
electric heat, 11
gas electric, 11
heat pump, 11
reversing valve, 11

Drain Pan Overflow

Alarm, *see Dry Contact*

Dry Contact

operation, 29
polarity, 29
service pan, 29
vacation, 29

Index

E

Electric Heating

AuxHeat icon, 5
dip switch setting, 11

Emergency Heat, 2, 18

F

Factory Defaults

settings, 33
resetting, 30

Fahrenheit, 30

Fan

button function, *see*
Buttons
on during heat, *see*
Electric Heat
on icon, 5
runtime, 23
2nd stage heat, *see*
Emergency Heat

G

Gas/Electric Furnace

jumper, 11

Green Cool Indicator, 1 Heat

1st stage deadband,
see Deadband
min. of runtime, 24
deadband, *see*
Deadband
droop, *see Deadband*
electric/heat pump, 11
icon, 3
indicator red, 1
mode, 1, 3, 6
program, *see Program*
runtime, *see Runtime*
setpoint, 7

H

Heat Pump

AuxHeat, 5, 11, 18, 24
emergency heat, 18
dip switch setting,
11multi-stage, 13
icon, 5

K

Keypad Lockout, 31

L

LCD, 3, 4, 5

Language, 16

Locked Indication,
see Keypad Lockout

M

Manual

changeover, 6
cool, 6, 7
heat, 6, 7

Mode, 3, 6, 7, 27

Multi-stage
Operation, 28

Index

N

Non-Programmable Thermostat, 27

Normally Open/Closed,
dry contact, 29

O

O Reversing Valve
see Reversing Valve
Off Mode, 3, 6

Outdoor
button, *see Buttons*
viewing temperature, 8

P

Pan, Service
see Dry Contact

Polarity, *see Dry Contact*

Program
Copy, 26
daily schedule, 26, 27
mode, 27
worksheet, *back page*

Programmable Thermostat, 27

Programming a Daily Schedule, 26, 27

R

Remote Sensor
viewing, 19

Reset
Alert Messages, 24
thermostat settings,
see Factory Defaults
runtime
fan/filter, 24
UV light, 25

Reversing Valve, 12

Runtime
resetting, *see Reset*
setting,
service filter, 23
UV light, 24
cool, 24
heat, 24
UV lamp, 24

S

Schedule
Daily, *see Program*

Sensor
outdoor, *see Outdoor*
remote, *see Remote*
thermostat, *see Thermostat*

Service
filter icon, *see Reset*
pan icon, *see Dry Contact*
UV light, *see Reset*

Set Clock, *see Clock*

Setpoint
cool, *see Cool*

Index

T

Technician Setup, 15, 32

Thermostat Sensor

calibrate, 15, 32

Time, see Clock

Time Delay,

compressor lockout, 28

cycles per hour, 28

Time Schedule,

see Program

Troubleshooting, 34

U

UV Light

resetting, 24

runtime, *see Runtime*

setting, *see Runtime*

V

Vacation

button, *see Buttons*

mode, 18

programming, 18

setpoints, 18

W

Wireless Module, 19

Warranty, 39

Wi-Fi, 20

Warranty

One-Year Warranty - This Product is warranted to be free from defects in material and workmanship. If it appears within one year from the date of original installation, whether or not actual use begins on that date, that the product does not meet this warranty, a new or remanufactured part, at the manufacturer's sole option to replace any defective part, will be provided without charge for the part itself provided the defective part is returned to the distributor through a qualified servicing dealer.

THIS WARRANTY DOES NOT INCLUDE LABOR OR OTHER COSTS incurred for diagnosing, repairing, removing, installing, shipping, servicing or handling of either defective parts or replacement parts. Such costs may be covered by a separate warranty provided by the installer.

THIS WARRANTY APPLIES ONLY TO PRODUCTS IN THEIR ORIGINAL INSTALLATION LOCATION AND BECOMES VOID UPON REINSTALLATION.

LIMITATIONS OF WARRANTIES – ALL IMPLIED WARRANTIES (INCLUDING IMPLIED WARRANTIES OF FITNESS FOR A PARTICULAR PURPOSE AND MERCHANTABILITY) ARE HEREBY LIMITED IN DURATION TO THE PERIOD FOR WHICH THE LIMITED WARRANTY IS GIVEN. SOME STATES DO NOT ALLOW LIMITATIONS ON HOW LONG AN IMPLIED WARRANTY LASTS, SO THE ABOVE MAY NOT APPLY TO YOU. THE EXPRESSED WARRANTIES MADE IN THIS WARRANTY ARE EXCLUSIVE AND MAY NOT BE ALTERED, ENLARGED, OR CHANGED BY ANY DISTRIBUTOR, DEALER, OR OTHER PERSON WHATSOEVER.

ALL WORK UNDER THE TERMS OF THIS WARRANTY SHALL BE PERFORMED DURING NORMAL WORKING HOURS. ALL REPLACEMENT PARTS, WHETHER NEW OR REMANUFACTURED, ASSUME AS THEIR WARRANTY PERIOD ONLY THE REMAINING TIME PERIOD OF THIS WARRANTY.

THE MANUFACTURER WILL NOT BE RESPONSIBLE FOR:

1. Normal maintenance as outlined in the installation and servicing instructions or owner's manual, including filter cleaning and/or replacement and lubrication.
2. Damage or repairs required as a consequence of faulty installation, misapplication, abuse, improper servicing, unauthorized alteration or improper operation.
3. Failure to start due to voltage conditions, blown fuses, open circuit breakers or other damages due to the inadequacy or interruption of electrical service.
4. Damage as a result of floods, winds, fires, lightning, accidents, corrosive environments or other conditions beyond the control of the Manufacturer.
5. Parts not supplied or designated by the Manufacturer, or damages resulting from their use.
6. Manufacturer products installed outside the continental U.S.A., Alaska, Hawaii, and Canada.
7. Electricity or fuel costs or increases in electricity or fuel costs for any reason whatsoever including additional or unusual use of supplemental electric heat.
8. ANY SPECIAL INDIRECT OR CONSEQUENTIAL PROPERTY OR COMMERCIAL DAMAGE OF ANY NATURE WHATSOEVER. Some states do not allow the exclusion of incidental or consequential damages, so the above may not apply to you.

This warranty gives you specific legal rights and you may also have other rights which may vary from state to state.

Programming Worksheet - see page 23

DAY	PERIOD	START TIME	COOL	HEAT	
MONDAY	Morning				
	Day				
	Evening				
	Night				
TUESDAY	Morning				<i>Copy Mon to Tues</i> <input type="checkbox"/> No <input type="checkbox"/> Yes
	Day				
	Evening				
	Night				
WEDNESDAY	Morning				<i>Copy Tues to Wed</i> <input type="checkbox"/> No <input type="checkbox"/> Yes
	Day				
	Evening				
	Night				
THURSDAY	Morning				<i>Copy Wed to Thurs</i> <input type="checkbox"/> No <input type="checkbox"/> Yes
	Day				
	Evening				
	Night				
FRIDAY	Morning				<i>Copy Thurs to Fri</i> <input type="checkbox"/> No <input type="checkbox"/> Yes
	Day				
	Evening				
	Night				
SATURDAY	Morning				<i>Copy Fri to Sat</i> <input type="checkbox"/> No <input type="checkbox"/> Yes
	Day				
	Evening				
	Night				
SUNDAY	Morning				<i>Copy Sat to Sun</i> <input type="checkbox"/> No <input type="checkbox"/> Yes
	Day				
	Evening				
	Night				

Patent Pending



Printed on recycled paper.
P/N 88-1206 Rev. 1 07/17

