

DAIKIN

Now with
Wi-Fi
On Board

High Resolution TouchScreen Digital Thermostat model DT4272 RESIDENTIAL



for
Residential Use



Owner's Manual & Installation Guide



CAUTION

Follow the Installation Instructions before proceeding. Set the thermostat mode to “OFF” prior to changing settings in setup or restoring Factory Defaults.

FCC Compliance Statement

This equipment has been tested and found to comply with the limits for an intentional radiator, pursuant to Part 15, subpart C of the FCC rules. These limits are designed to provide reasonable protection against harmful interference in a residential installation. This equipment generates, uses and can radiate radio frequency energy and, if not installed and used in accordance with the instructions, may cause harmful interference in radio communications. However, there is no guarantee that the interference will not occur in a particular installation. If this equipment does cause harmful interference to radio or television reception, which can be determined by turning the equipment off and on, the user is encouraged to try to correct the interference by one or more of the following measures:

- Reorient or relocate the receiving antenna.
- Increase the separation between the equipment and receiver.
- Connect the equipment into an outlet on a circuit different from that of the receiver.
- Consult the dealer or an experienced radio or TV technician for help.

Notice: Only peripherals complying with FCC limits may be attached to this equipment. Operation with noncompliant peripherals or peripherals not recommended by Daikin, is likely to result in interference to radio and TV reception. Changes or modifications to the product, not expressly approved by Daikin could void the user's authority to operate the equipment.

FCC - INDOOR Mobile Radio Information:

To comply with FCC/IC RF exposure limits for general population / uncontrolled exposure, the antenna(s) used for this transmitter must be installed to provide a separation distance of at least 20 cm from all persons and must not be co-located or operating in conjunction with any other antenna or transmitter.

This Device complies with Industry Canada License-exempt RSS standard(s). Operation is subject to the following two conditions: 1) this device may not cause interference, and 2) this device must accept any interference, including interference that may cause undesired operation of the device.

Under Industry Canada regulations, this radio transmitter may only operate using an antenna of a type and maximum (or lesser) gain approved for the transmitter by Industry Canada. To reduce potential radio interference to other users, the antenna type and its gain should be so chosen that the equivalent isotropically radiated power (e.i.r.p.) is not more than that necessary for successful communication.

Cet appareil est conforme avec Industrie Canada, exempts de licence standard RSS(s). Son fonctionnement est soumis aux deux conditions suivantes: 1) ce dispositif ne doit pas causer d'interférences, et 2) ce dispositif doit accepter toute interférence, y compris les interférences qui peuvent causer un mauvais fonctionnement de l'appareil.

En vertu des règlements d'Industrie Canada, cet émetteur de radio ne peut fonctionner en utilisant une antenne d'un type et maximale (ou moins) Gain approuvé pour l'émetteur par Industrie Canada. Pour réduire les interférences radio potentielles aux autres utilisateurs, le type d'antenne et son gain doivent être choisis afin que la puissance isotrope rayonnée équivalente (PIRE) ne est pas plus de ce qui est nécessaire pour une communication réussie.

We, Daikin, declare under our sole responsibility that the device to which this declaration relates: Complies with Part 15 of the FCC Rules. Operation is subject to the following two conditions: (1) this device may not cause harmful interference, and (2) this device must accept any interference received, including interference that may cause undesired operation.

The FCC responsible party is Goodman Manufacturing Company, L.P., and may be contacted by calling (713)-861-2500, or at 19001 Kermier Rd., Waller, TX 77484. www.GoodmanMFG.com

This color touchscreen has the ability to receive updates to its firmware. Periodically firmware updates are released by the manufacturer to add features and/or performance enhancements. This manual was produced reflecting the most current firmware/feature set at the time of publication, firmware rev. 4.04. Firmware releases after rev. 4.04 may not be adequately depicted in this manual. Please refer to the appropriate website or contact your place of purchase to learn about changes to the thermostat after firmware release 4.04.



Innovation, Science and Economic Development Canada
ICES-003 Compliance Label: CAN ICES-3 (B)/NMB-3(B)
IC: 12547A-SKYP0RT15

Glossary of Terms

- Auto-Changeover:** A mode in which the thermostat will turn on the heating or cooling based on room temperature demand.
- Cool Setpoint:** The warmest temperature that the space should rise to before cooling is turned on (without regard to deadband).
- Deadband:** The number of degrees the thermostat will wait, once a setpoint has been reached, before energizing heating or cooling.
- Differential:** The forced temperature difference between the heat setpoint and the cool setpoint in Auto Mode.
- Heat Setpoint:** The coolest temperature that the space should drop to before heating is turned on (without regard to deadband).
- Icon:** The word or symbol that appears on the thermostat display.
- Mode:** The current operating condition of the thermostat (i.e. Off, Heat, Cool, Auto).
- Non-Programmable Thermostat:** A thermostat that does not have the capability of running Time Period Programming.
- Programmable Thermostat:** A thermostat that has the capability of running Time Period Programming.
- Temperature Swing:** Same as Deadband.
- Time Period Programming:** A program that allows the thermostat to automatically adjust the heat setpoint and/or the cool setpoint based on the time of the day. Same as Schedule.

Table of Contents

GET TO KNOW YOUR THERMOSTAT

Home Screen	1
Menu Screens.....	1
Dropdown Dashboard	2
Care and Use of Your Thermostat	3

QUICK START

Selecting Your Desired Temperature and Mode.....	4
Time Period Schedule.....	4
Using the Fan Button	4
Setting the Time & Date.....	5
Setting the Time.....	6
Setting the Date	7
Daylight Savings Setup.....	7
Connecting to Wi-Fi.....	8
WiFi Set up - Create a Skyport Account.....	10

MAIN MENU BUTTONS

SCHEDULE.....	11
View My Schedule.....	12
Edit My Schedule	12
SMART FAN.....	14
Smart Fan On/Off	15
Smart Fan Minimum Runtime.....	15
Start/Stop Times	15
Days to allow Smart Fan operation.....	15
SCREENSAVER	16
Screensaver On/Off	17
ScreensaverSetup	17
Screensaver Preview.....	17
ALERTS	18
View Current Alerts.....	19
Reset Alerts	19
Set/Edit Reminders.....	19
Service Information (Who To Call For Service)	19

Table of Contents

DISPLAY	20
Active Brightness	21
Idle Brightness	21
Night Dimmer	21
Maintenance.....	22
PREFERENCES	23
User Interface Themes	24
Custom Wallpaper	24
Heat/Cool Indicator.....	24
Sound Options	24
VACATION/AWAY	25
Clear Vacation Schedule.....	26
Set Vacation Schedule.....	26
Schedule.....	27
Modes & Setpoints	27
SECURITY	28
Auto Screenlock	29
Setpoint Limits	29
INFORMATION	30
My Thermostat	31
View Runtime Graphs	31
Who to Call for Service.....	31
SETTINGS.....	32
Thermostat Name.....	36
Available Modes	36
SD Card (Import and Export).....	36

Table of Contents





GENERAL SETUP	36
Units (F or C).....	36
Language	37
Smart Recovery On/Off.....	37
Simple Thermostat On/Off.....	37
AUTOMATED DEMAND RESPONSE	38
INSTALLATION SETTINGS	52
Heat & Cool Stages.....	52
Heat & Cool Stages.....	52
Compressor Stages	52
Aux Heat Stages	52
Timers & Deadbands	52
Free Cooling	54
Heat Pump Settings.....	55
Heat Pump Lockout - Enabled/Disabled	55
Heat Pump Lockout Outdoor Temp	55
Aux Heat Lockout Enabled/Disabled	55
Aux Heat Lockout Temp	55
Dual Fuel Settings.....	55
Dual Fuel On/Off.....	55
Changeover With Outdoor Temp On/Off.....	55
Adjust Balance Point.....	55
AUX Output Settings.....	56
Fan Off Delay.....	57
Sensor Settings.....	57
Control Sensor	57
Wired Sensor	57
Calibrate Sensors.....	57
Test Outputs	57
Dealer Information	58
Upgrade Firmware	58
Delete Custom Images	58
Calibrate Clock	58

Table of Contents

Reset to Factory Default Settings	58
Restart Thermostat	58
WI-FI	59
Status.....	59
Setup	59
Local API	61
SKYPORT	64
Account.....	64
EMERGENCY HEAT	65
TOUCHSCREEN ASSISTANT	66
Installing the TouchScreen Assistant Software	66
Uploading Photos	66
INSTALLATION INSTRUCTIONS.....	68
Remove & Replace the Old Thermostat	68
Wire Connections.....	69
Determining Your Existing Wiring and Equipment	70
Making 4 Wires Work When 5 Wires Are Required.....	72
Making 5 Wires Work When 6 Wires Are Required.....	73
The Thermostat Backplate.....	74
Explanation Of the Thermostat Dip Switches.....	75
Sample Wiring Diagrams	76
TROUBLESHOOTING.....	79
INDEX	80
WARRANTY	84

Get To Know Your Thermostat

Home Screen

Connectivity Symbol Table	
	Not connected to Wi-Fi
	Connected to local access point w/IP address without Skyport enabled
	Connected to local access point w/IP address, but not yet connected to Skyport
	Connected to Skyport

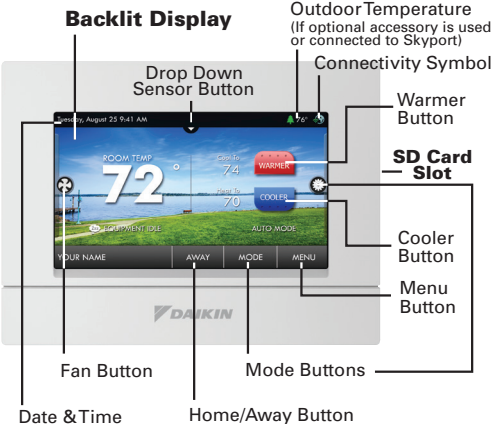

The Home Screen diagram shows a thermostat display with the following labels and functions:

- Backlit Display**: The main display area.
- Drop Down Sensor Button**: A button to toggle sensor input.
- Outdoor Temperature**: (If optional accessory is used or connected to Skyport) Shows current outdoor temperature (76°).
- Connectivity Symbol**: Shows the current Wi-Fi or Skyport connection status.
- Warmer Button**: A red button to increase temperature.
- SD Card Slot**: A slot for an SD card.
- Cooler Button**: A blue button to decrease temperature.
- Menu Button**: A button to access the main menu.
- Mode Buttons**: Buttons for AWAY, MODE, and MENU.
- Fan Button**: A button to control the fan.
- Date & Time**: Shows the current date and time (Tuesday, August 25 9:43 AM).
- Home/Away Button**: A button to toggle between Home and Away modes.

Main Menu Screen

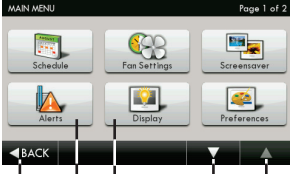

The Main Menu Screen shows a grid of icons for various settings:

- Schedule
- Fan Settings
- Screensaver
- Alerts
- Display
- Preferences

Navigation buttons at the bottom include:

- Back Button**: A left-pointing arrow.
- Menu Buttons**: A central downward-pointing arrow.
- Scrolling Buttons**: Upward and downward-pointing arrows.

Sub Menu Screen

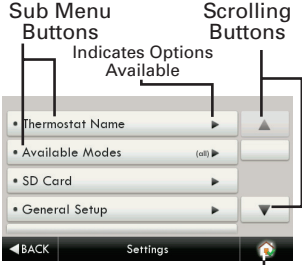

The Sub Menu Screen shows a list of settings with navigation options:

- Sub Menu Buttons**: Left-pointing arrows next to each menu item.
- Scrolling Buttons**: Upward and downward-pointing arrows on the right side.
- Indicates Options Available**: A right-pointing arrow next to the menu item.
- Home Button**: A circular button at the bottom right.

Navigation buttons at the bottom include:

- Back Button**: A left-pointing arrow.
- Settings**: The current menu name.
- Home Button**: A circular button.

Get To Know Your Thermostat

Dropdown Dashboard



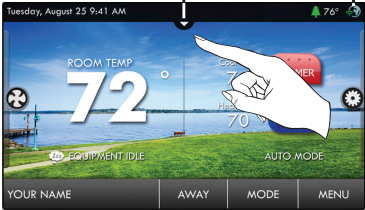

The Dropdown Dashboard displays temperature, humidity, and other readings. It will also show the high and low readings of the day.

Drop Down Dashboard Button

Wi-Fi Connection Icon



Connectivity Symbol Table

	Not connected to Wi-Fi
	Connected to local access point w/IP address without Skyport enabled
	Connected to local access point w/IP address, but not yet connected to Skyport
	Connected to Skyport

Dropdown Dashboard

(The contents of your Dashboard may vary)

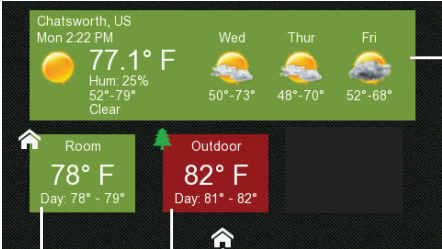

Weather Display

Chatsworth, US
Mon 2:22 PM

77.1° F
Hum: 25%
52°-79°
Clear

Wed 50°-73°
Thur 48°-70°
Fri 52°-68°

Room Temp
78° F
Day: 78° - 79°

Outdoor Temp
82° F
Day: 81° - 82°

Press the HOME button to return to the Home Screen

Get To Know Your Thermostat

Care and Use of Your Thermostat

Pencils, pens and other sharp objects should never be used on your thermostat; these may damage your touchscreen. Only use your finger tip to press the touchscreen buttons.



Use a soft, damp cloth to clean the screen.

DO NOT USE ABRASIVE CLEANERS OR CLEANERS THAT CONTAIN SOLVENTS. DO NOT SPRAY ANYTHING DIRECTLY ONTO THE THERMOSTAT.

Quick Start - Temperature, Modes & Fan



Selecting Your Desired Temperature and Mode

Press  or  to adjust temperature

The Heat or Cool Setpoint is the temperature the room has to reach before heating or cooling will turn on.

(Without regard to deadband)



Press  or the **MODE** Icon 

HEAT will allow only heat operation.

COOL will allow only cool operation.

AUTO will allow both Heat and Cool operation.



OFF - heating and cooling systems are turned off.

AUTO-CHANGEOVER MODE - Pressing the WARMER or COOLER buttons in Auto mode will adjust both the heat and cool setpoints simultaneously. To adjust heat and cool setpoints individually, choose HEAT mode to adjust the heat setpoint and COOL mode to adjust the cool setpoint, then return to AUTO mode.

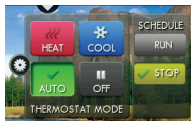
HEAT OR COOL MODE - Pressing the WARMER or COOLER buttons in Heat or Cool mode will adjust only the heat or cool setpoints.



Time Period Schedule

Press  or the **MODE** Icon 

To turn on the preprogrammed time period schedule, select **RUN**.

To turn off the preprogrammed time period schedule, select **STOP**.

Using the Fan Button

Press the **FAN** Icon 

FAN ON fan runs constantly even in OFF Mode.

FAN AUTO fan only runs with a heating or cooling demand.



Quick Start - Set Time & Date



NOTE: When the thermostat is connected to a Skyport account, the Time & Date are automatically synchronized to the Skyport Cloud, including automatic Daylight Savings adjustments. Your time zone is selected in the Skyport web application.

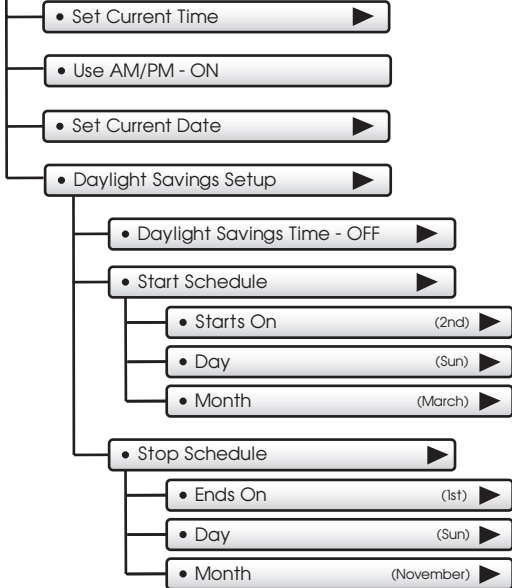

Quick Start - Set Time & Date

Setting the Time

Press **MENU** then **▼** to scroll down.

Press  **Set Time & Date**

Press

• Set Current Time (12:00 AM) 

Press   and   to set the current time.

Press **◀ BACK** when finished.

Choose

• Use AM/PM - ON 

For 12 hour AM/PM clock

• Use AM/PM - OFF 

For 24 hour clock

Press **◀ BACK** when finished.

Quick Start - Set Time & Date

Setting the Date

• Set Current Date 6/1/2013 ▶  Press

Press ◀ or ▶ to set the current month and year.

Press the day on the calendar

Su	Mo	Tu	We	Th	Fr	Sa
27	28	29	30	1	2	3
4	5	6	7	8	9	10
11	12	13	14	15	16	17
18	19	20	21	22	23	24
25	26	27	28	29	30	31
1	2	3	4	5	6	7

◀ ▶

Press ◀ BACK when finished.

• Daylight Savings Setup ▶

Turn Daylight Savings Time on or off.

• Daylight Savings Time - OFF

• Daylight Savings Time - ON 

Adjust when Daylight Savings Time begins.

• Start Schedule

Adjust when Daylight Savings Time ends.

• Starts On (2nd) ▶

• Day (Sun) ▶

• Month (March) ▶

Press ◀ BACK

after making a change to a selection.

• Stop Schedule ▶

• Ends On (1st) ▶

• Day (Sun) ▶

• Month (November) ▶

Press ◀ BACK

or the Home button when finished.

Quick Start - Connect to Wi-Fi

Connect to Wi-Fi (from initial start up)

When power is connected to the thermostat and it has not been configured to connect to a Wi-Fi Access point, the following message appears:

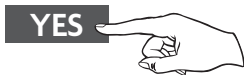
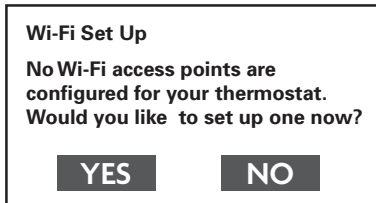

Press YES

Select the access point you wish to connect to from the list.



Enter the password for the Wi-Fi Access Point and press **NEXT**.



Select automatic setup and press **NEXT**.



When finished, a dialog box will appear confirming the successful connection to the local Wi-Fi Access Point.



Select **OK**, then the Wi-Fi status page will appear. Upon closing of the Wi-Fi status page, you will be asked to join the thermostat to a Skyport account.



Select **YES** and follow the onscreen instructions to create a new Skyport account or to add the thermostat to an existing account.

Quick Start - Connect to Wi-Fi (from menus)

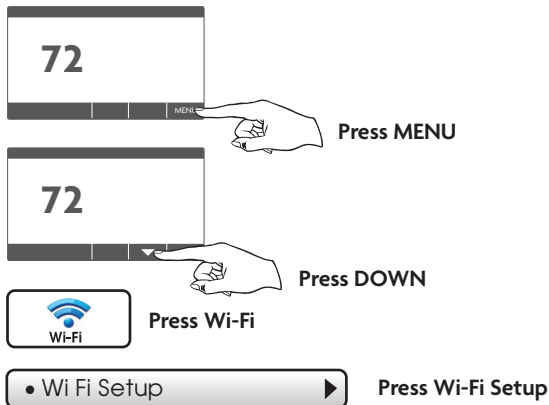

Select the access point from the list that you want to connect to.



Enter the password for the Wi-Fi Access Point and press **NEXT**.



Select automatic setup and press **NEXT**.



When finished, a dialog box will appear confirming the successful connection to the local Wi-Fi Access Point.



Select **OK**, then the Wi-Fi status page will appear. Upon closing of the Wi-Fi status page, you will be asked to join the thermostat to a Skyport account.



Select **YES** and follow the onscreen instructions to create a new Skyport account or to add the thermostat to an existing account.

Quick Start - Connect to Wi-Fi (from menus)

Although there is more than one way to create a Skyport account, the steps below illustrate creation from a browser.

If the thermostat is connected to the local Wi-Fi Access Point, but not yet joined to a Skyport account, you may join the thermostat to an account by doing the following:

Select **MENU** from the thermostat's home screen.



Scroll down



Select Skyport



Select Skyport Account and follow the onscreen instructions.



1. Open your browser to: <https://Daikin.skyportcloud.com>
2. Select "Create account now"



3. Follow on screen instructions to create an account and add a thermostat to the Skyport account.

Main Menu Buttons - Schedule

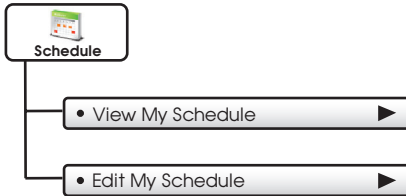

Main Menu Buttons - Schedule



Schedule

This thermostat features up to four programmable time periods per 24 hour day: Morning, Day, Evening, and Night. The start time for each time period is adjustable. The stop time for each time period is the start time for the next period.

• View My Schedule

Press a day of the week to view its settings. This may be repeated for each day.

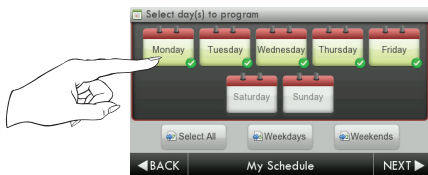

• Edit My Schedule

Press and select days to program

Select individual days

or

Select groups of days

Then press **NEXT**

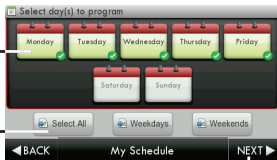

Continued ►

Main Menu Buttons - Schedule

• Edit My Schedule

(Continued)

Press and select a Time Period (Morning, Day, Evening, or Night) to edit.



Adjust Mode, Start Time, and Heat and Cool Setpoints to desired settings. The Time Period may also be Enabled or Disabled. Un-check the Enabled box for Time Periods you don't want to use. Press **DONE** when finished.

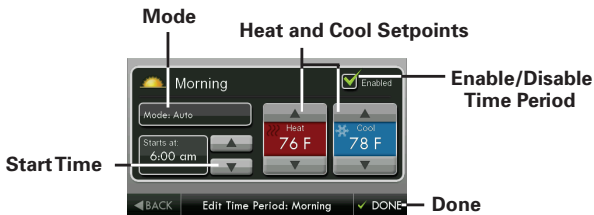

When you are finished editing the four time periods press

NEXT

Review your program.
Press **SAVE** to keep your program.
Press **EDIT** to make further changes.

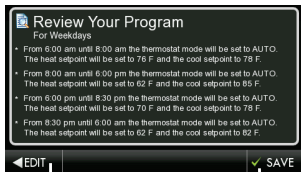

Edit

Save

Main Menu Buttons - Smart Fan

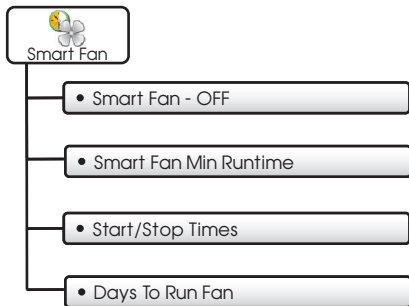

Main Menu Buttons - Smart Fan



Smart Fan

The fan may be programmed to turn on automatically for a specified period during the day.

Press to turn fan schedule on or off

• Smart Fan - OFF

• Smart Fan - ON



• Smart Fan Min Runtime

(10m) ▶

Set the minimum number of minutes the fan will run from the top of each hour. Set runtime to 60 minutes to be on continuously from StartTime to Stop time. (5 - 60 mins.)

• Start/Stop Times

(7:00AM - 9:00PM) ▶

Set when the Smart Fan schedule will start and stop. For example, you may not want Smart Fan to run during sleeping hours.

• Days To Run Fan



Choose which days of the week Smart Fan will run.

Main Menu Buttons - Screensaver

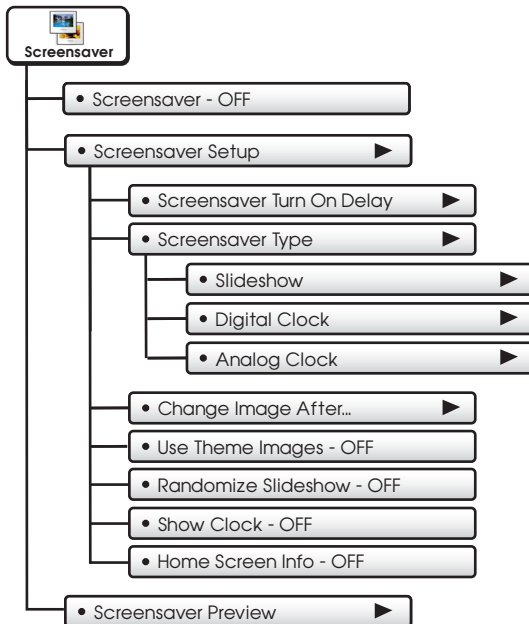

Main Menu Buttons - Screensaver



The Screensaver allows you to create custom slideshows.

• Screensaver - OFF

• Screensaver - ON 

• Screensaver Setup 



• Screensaver Turn On Delay (5m) 

How long after a button press for the Screensaver to appear. 1, 3, 5, or 30 minutes

• Screensaver Type (Slideshow) 

Slideshow, Digital Clock, Analog Clock

• Change Image After... 

15, 30 seconds - 1, 5, or 10 minutes

• Use Theme Images - OFF 

Slideshow uses included Theme Images. Off or On

• Randomize Slideshow - OFF 

Shuffles slideshow photos in random order

• Show Clock - OFF 

Shows the time and date every 5 photos. Off or On

• Home Screen Info - OFF 

Shows the mode, setpoints, and temperature after every 10 photos. Off or On.

• Screensaver Preview 

Press this button to preview your screensaver operation before returning to the Home Screen.

After the preview, press anywhere on the screen to return to the sub menu.

Main Menu Buttons - Alerts

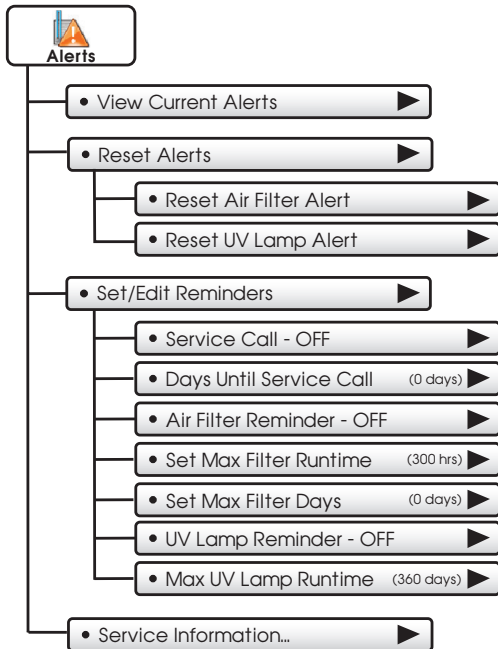

Main Menu Buttons - Alerts



The alerts let you know when your system needs service.

• View Current Alerts

View and reset current service alerts here.

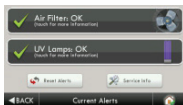

Alerts will appear on the bottom bar of the Home Screen. Press to view and reset current alerts.



• Reset Alerts

Clear and reset current service alerts.

• Set/Edit Reminders

Set service alert runtimes and turn reminders on or off.

• Service Call Reminder - OFF

• Days Until Service Call (0 days)

• Air Filter Reminder - OFF

• Set Max Filter Runtime (500 hrs)

• Set Max Filter Days (300 days)

• UV Lamp Reminder - OFF

• Set Max UV Lamp Runtime (300 days)

• Service Information...

View your service company's contact information.

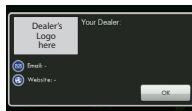

Main Menu Buttons - Display

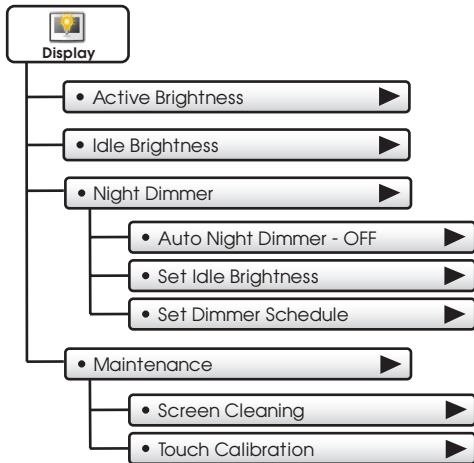

Main Menu Buttons - Display



Display

The display brightness options may be adjusted in this menu.

- Active Brightness (80%) ▶

You may select how bright the backlight is while the thermostat is active. The display is active for 3 minutes after last touch, it then goes Idle.

- Idle Brightness (30%) ▶

You may select how bright the backlight is while the thermostat is idle.

- Night Dimmer ▶

You may dim the brightness of the screen at night.

- Auto Night Dimmer - OFF

The screen can be set to dim automatically at night. Dimming the display can prolong the life of the backlight.

- Set Idle Brightness (20%) ▶

Set the screen brightness for the Night Dimmer. When Night Dimmer is On, the display will go idle 8 seconds after last touch.

- Set Dimmer Schedule ▶

Set the schedule for the Night Dimmer.

Main Menu Buttons - Display

• Maintenance

Maintenance allows you to clean and calibrate the touch screen.

• Screen Cleaning

Screen Cleaning Mode disables the touch feature for 15 seconds so the screen may be cleaned without altering any settings.



Use a soft cloth without solvents or abrasive cleaners

• Touch Calibration

Under normal circumstances, the touchscreen should not need to be calibrated.

Touch and hold the center of the targets as they appear on the screen for 3 seconds.

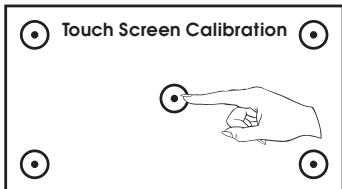

Press **FINISH** when done.

When calibration is complete, the thermostat will automatically restart and return to the Home Screen.

Main Menu Buttons - Preferences

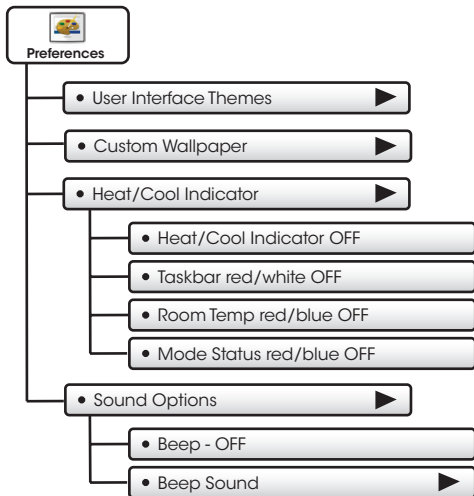

Main Menu Buttons - Preferences



Preferences

You may set the type of background that appears on the thermostat Home Screen.

• User Interface Themes (ocean) ▶

This thermostat has several high quality background themes to choose from.

NOTE: At 7pm, the background will change to an evening scene.

At 7am it will return to a daytime scene.

• Custom Wallpaper ▶

You may choose your own background image by selecting a photo that you have uploaded from an SD memory card.

• Heat/Cool Indicator ▶

You may choose an enhanced indicator of the current status of the HVAC equipment.

- Heat/Cool Indicator - ON/OFF
- Room Temp Red/Blue - ON/OFF
- Taskbar Red/White - ON/OFF
- Mode Status Red/Blue - ON/OFF

• Sound Options ▶

• Beep - ON 

• Beep - OFF

Turn the beep sound on or off.

• Beep Sound (Beep 1) ▶

Choose from different beep sounds.

Main Menu Buttons - Vacation/Away

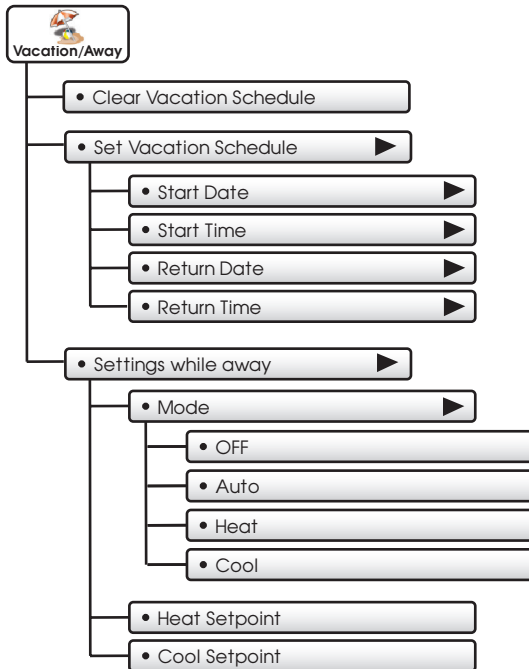

Main Menu Buttons - Vacation/Away



Vacation or pressing the AWAY button, will use temporary, energy saving settings without changing the regular schedule. Pressing the HOME button will return the thermostat to normal comfort settings.

• Clear Vacation Schedule

Removes the stored vacation schedule.

• Set Vacation Schedule

Set your Vacation Schedule.

• Start Date

Tue Sep 07 2010

Select the day Vacation Mode will start.

Then press **BACK**



BACK

• Start Time

(9:00 AM)

Select the time Vacation Mode will start.

Then press **BACK**

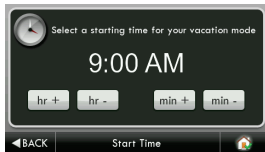

Continued **▶**

Main Menu Buttons - Vacation/Away

• Set Vacation Schedule ▶

(Continued)

• Return Date Tue Sep 21 2010 ▶

Select the day Vacation Mode will end.

Then press **◀ BACK**



• Return Time (3:00 PM) ▶

Select the time Vacation Mode will end.

Then press **◀ BACK**



• Settings while away ▶

Select the desired Mode and setpoints to be used in Vacation/Away Mode.

• Mode (Auto) ▶

• Heat Setpoint (50°) ▶

• Cool Setpoint (85°) ▶

Main Menu Buttons - Security

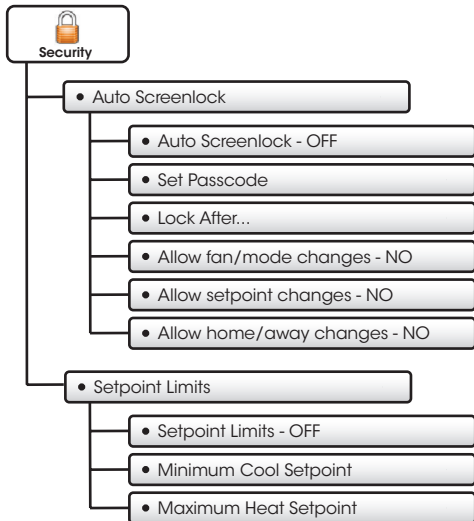

Main Menu Buttons - Security



Security

Security settings may be set to limit or prevent changes to your thermostat.

• Auto Screenlock

• Auto Screenlock - OFF

• Auto Screenlock - ON

• Set Passcode (code not set)

NOTE: Code must be set before Auto Screenlock can be turned on.

Use keypad to enter and confirm passcode.



When the thermostat is locked, the bottom bar of the display will show:

UNLOCK



Press UNLOCK then enter passcode to access thermostat settings.

• Lock After... (5 m)

Set the time the screen will automatically lock after the last button press.

• Allow fan/mode changes - NO

Choose to allow fan/mode changes when Auto Screenlock is on.

• Allow setpoint changes - NO

Choose to allow setpoint changes when Auto Screenlock is on.

• Allow home/away changes - NO

Choose to allow use of the Home and Away button when Auto Screenlock is on.

• Setpoint Limits

Limits how high or low heating and cooling may be adjusted.

Main Menu Buttons - Information

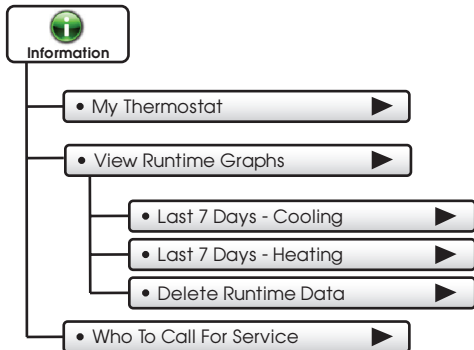

Main Menu Buttons - Information



This button contains valuable service and system runtime information.

• My Thermostat

View your thermostat dip switch settings, equipment status, runtimes, and other settings.

• View Runtime Graphs

Track your system's runtime/energy usage.

• Last 7 Days - Cooling

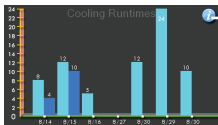

Press the information icon to learn more about each graph

*NOTE: The runtime graphs are updated at 12:00 AM each day.

• Last 7 Days - Heating



Press anywhere on the screen to return to the submenu.

• Delete Runtime Data

Press to delete your current equipment runtime information.

• Who To Call For Service

Your service company's contact information may be displayed here.

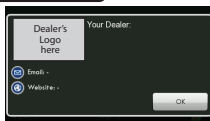

Main Menu Buttons - Settings

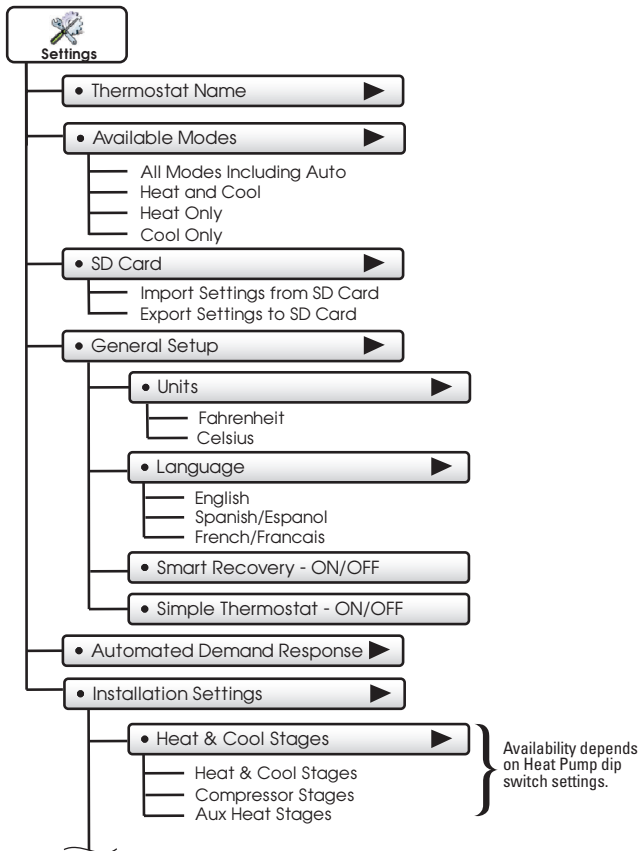

(Continued next page)

Main Menu Buttons - Settings

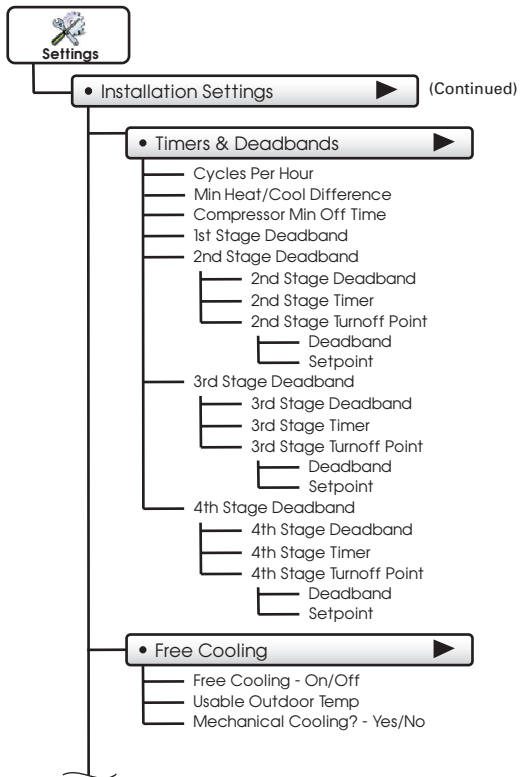

(Continued next page)

Main Menu Buttons - Settings



• Installation Settings ▶ (Continued)

• Heat Pump Settings ▶

- Heat Pump Lockout - Enabled/Disabled
- HP Lockout Outdoor Temp
- Aux Heat Lockout - Enabled/Disabled
- Aux Heat Lockout Temp
- Dual Fuel Settings
 - Dual Fuel - On/Off
 - Changeover With Outdoor - On/Off
 - Adjust Balance Point

• AUX Output Settings

- AUX Output Usage
- AUX Output Polarity

• Fan Off Delay ▶

• Sensor Settings ▶

- Control Sensor
 - Thermostat Sensor Only
 - Wired Sensor Only
 - Average Wired/Thermostat
- Wired Sensor Use
 - Use as Outdoor Sensor
 - Use as Remote Sensor
 - Use as Supply Sensor
 - Use as Return Sensor
- Calibrate Sensors
 - Thermostat
 - Wired Sensor

(Continued next page)

Main Menu Buttons - Settings

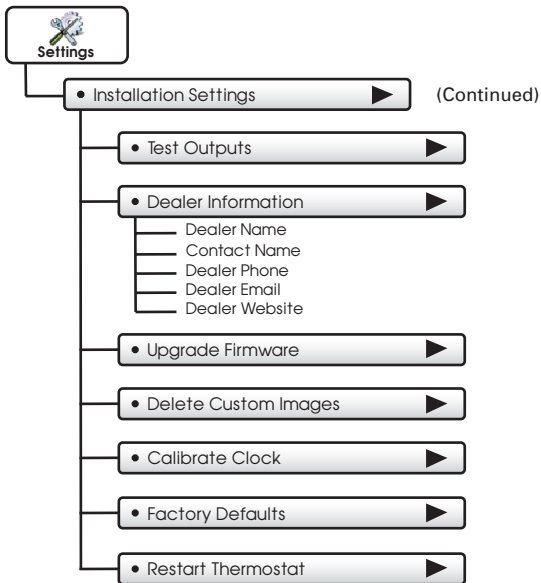

Main Menu Buttons - Settings



Thermostat heating and cooling options are found in this menu

• Thermostat Name

Use keypad to name your thermostat. The name is displayed on the Home Screen.

(Up to 14 characters)

Name appears here



• Available Modes (all)

Choose the desired modes the thermostat will use: Heat, Cool, Heat & Cool, or Auto (All). For example, if you only have a heater, choose Heat, and only Heat & Off modes will be available. This will simplify the operation for the user.

• SD Card

Import and export files to and from the thermostat. See the **TouchScreen Assistant** instructions for further details.

• Import Settings from SD Card

Upload files from TouchScreen Assistant or another thermostat.

• Export Settings to SD Card

Export files from one thermostat and import them into others.

***NOTE:** A 2GB SD card is recommended. To import and export files, the SD card must contain the same version of the firmware as the thermostat. TouchScreen Assistant will keep the firmware current.

• General Setup

• Units

- Fahrenheit (F)
- Celsius (C)

Main Menu Buttons - Settings

• General Setup

(Continued)

• Language

(en)

- English
- Spanish/Español
- French/Français

• Smart Recovery - OFF

• Smart Recovery - ON

Smart Recovery turns on the heat or cool before the Morning start time to bring the room temperature to the Morning setpoint at the start of the Morning time period. Please allow 4-8 days for Smart Recovery time to adjust. When used with a heat pump, electric strip heat will be disabled while Smart Recovery is active.

• Simple Thermostat - OFF

• Simple Thermostat - ON

Turn on Simple Thermostat for the most basic user interface.

When Simple Thermostat is on, alerts will appear in the top bar of the main screen. Press on the top yellow alert bar to view alerts.



Note: When using the SimpleThermostat Home Screen; the program schedule along with the **HOME** and **AWAY** features are unavailable.

Main Menu Buttons - Settings

- Automated Demand Response ►

Overview

TouchScreen thermostats support the handling of specific signals from the utility provider. The utility generated signals carry pricing information and/or setback actions that alter the comfort settings of the thermostat in order to reduce energy usage on demand. This is known as **Automated Demand Response** or ADR for short. You must register to participate in a utility sponsored program, if offered by your local utility, to take advantage of this feature.

SKYPORT CLOUD SERVICES

From the web application the user will select **Thermostat Settings** from the left column. Then the **Demand Response** button is selected.

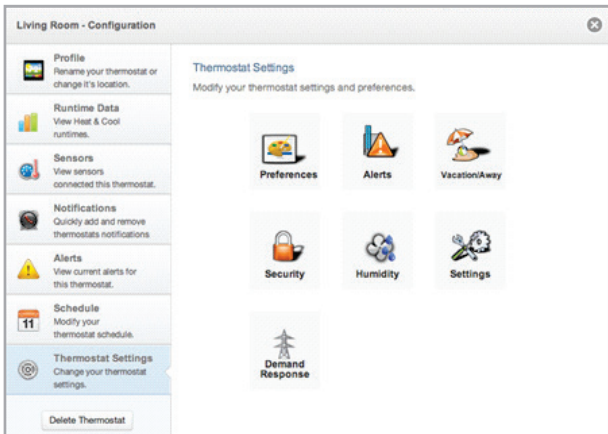

Main Menu Buttons - Settings

The Demand Response configuration page, shown below, is where the thermostat is configured to respond to the energy provider's signals. It also sets operational parameters for the thermostat.

The left column of the ADR configuration page allows or prevents access by the utility. Here communication with the utility and your thermostat may be turned On or Off.

The selected utility will provide a Program ID.

The Account ID would normally be the occupants utility account number.

Living Room - Configuration

Profile
Rename your thermostat or change it's location.

Runtime Data
View Heat & Cool runtimes.

Sensors
View sensors connected this thermostat.

Notifications
Quickly add and remove thermostats notifications

Alerts
View current alerts for this thermostat.

Schedule
Modify your thermostat schedule.

Thermostat Settings
Change your thermostat settings.

Delete Thermostat

Automated Demand Response

Configuration Overview



Demand Response

ON OFF

[What is Demand Response?](#)

Select Utility
LADWP

Program Id:
test-program

Account Id:
1234

Min & Max Settings

Event Max Cool Setpoint: 85° F

Event Min Heat Setpoint: 65° F

Static Settings

Static Cool Setpoint: 78° F

Static Heat Setpoint: 65° F

Offset Settings

Cool Setpoint Offset: +2

Heat Setpoint Offset: -2

Price Settings

Price Trigger: 45

Price Dependent Action: Observe Setpoint Offsets

Cancel Save

Main Menu Buttons - Settings

The right column of the ADR configuration page is where the occupant adjusts the operational parameters for ADR. The utility may send up to 3 types of ADR signals to Skyport. These are:

1) Pricing for the cost of energy, **2) An Offset** to the occupants' comfort setpoints, and **3) a signal** to enforce discrete or Static setpoints.

The Maximum Cooling Setpoint and Minimum Heating Setpoints for ADR events are adjusted here.

The Static Settings are applied when the utility sends a signal to allow the occupant to enforce their own discrete temperature settings during an ADR event.

The Offset Settings allow the utility to modify the Cool or Heat setpoints by the value set here during an ADR event.

A Price Trigger setting allows the occupant to set the maximum cost of energy threshold. When this threshold is exceeded the Price dependent action is enforced. This Price Trigger and Dependent action is enforced independent of an ADR event, as long as the utility sends 'real-time' pricing.

Living Room - Configuration

Profile
Rename your thermostat or change its location.

Runtime Data
View Heat & Cool runtimes.

Sensors
View sensors connected to this thermostat.

Notifications
Quickly add and remove thermostat notifications.

Alerts
View current alerts for this thermostat.

Schedule
Modify your thermostat schedule.

Thermostat Settings
Change your thermostat settings.

Delete Thermostat

Automated Demand Response

Configuration Overview

Demand Response
ON OFF
[What is Demand Response?](#)

Select Utility
LADWP

Program Id:
test-program

Account Id:
1234

Min & Max Settings

Event Max Cool Setpoint: 85°F	Event Min Heat Setpoint: 65°F
----------------------------------	----------------------------------

Static Settings

Static Cool Setpoint: 78°F	Static Heat Setpoint: 65°F
-------------------------------	-------------------------------

Offset Settings

Cool Setpoint Offset: +2	Heat Setpoint Offset: -2
-----------------------------	-----------------------------

Price Settings

Price Trigger:
45

Price Dependent Action:
Observe Setpoint Offsets

Cancel Save

Main Menu Buttons - Settings

Selecting the Overview tab of the ADR page will cause a summary of ADR events to be displayed.

The screenshot shows a 'Living Room - Configuration' window with a sidebar menu on the left and a main content area on the right. The sidebar menu includes: Profile, Runtime Data, Sensors, Notifications, Alerts, Schedule, and Thermostat Settings. The main content area is titled 'Automated Demand Response' and has two tabs: 'Configuration' and 'Overview'. The 'Overview' tab is active and displays a table of ADR events. Below the table are 'Cancel' and 'Save' buttons. The background of the main window shows icons for Security, Humidity, Settings, and Demand Response.

Living Room - Configuration

Automated Demand Response

Configuration Overview

Event Id	Event Type	Status	Start Time	Stop Time
1233407844	Price	Success	08/10/2014 1:00pm	08/10/2014 2:00pm
1233407844	Price	Success	08/15/2014 4:00pm	08/15/2014 5:00pm

Cancel Save ✓

Security Humidity Settings Demand Response

Main Menu Buttons - Settings

- Automated Demand Response ▶

Utility and Program setup must be done at the Skyport Cloud Services account. From the thermostat Home Screen, press the 'Menu' button, then select 'Settings'.

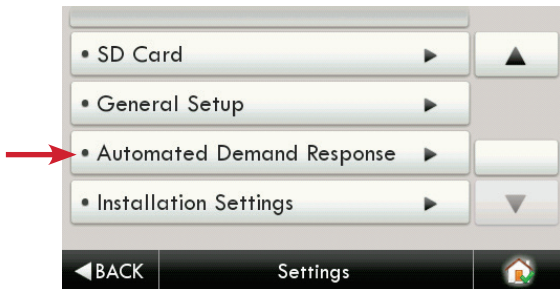

From the above screen the 'Automated Demand Response' button is pressed.

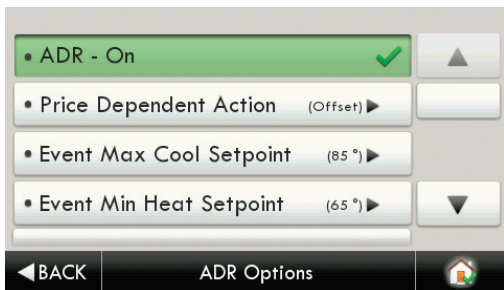

By selecting ADR – On, the user can participate in ADR events triggered by their utility, or price dependent events.

Main Menu Buttons - Settings

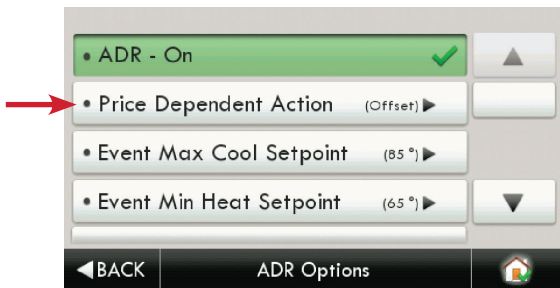

Selecting the 'Price Dependent Action' button allows the user to determine what action is taken when the price rises above the set threshold.

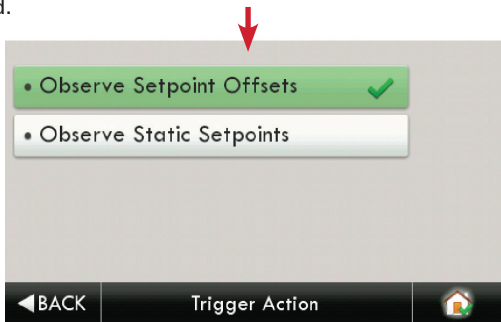

In the above example; if the price threshold is exceeded, the thermostat will invoke the 'Offset Setpoints' configured for an ADR event until the event is over.

Please note that the Threshold price may only be set in the Skyport Cloud Services account.

Selecting 'Skip Event' will take no action when the set price threshold is exceeded.

Main Menu Buttons - Settings

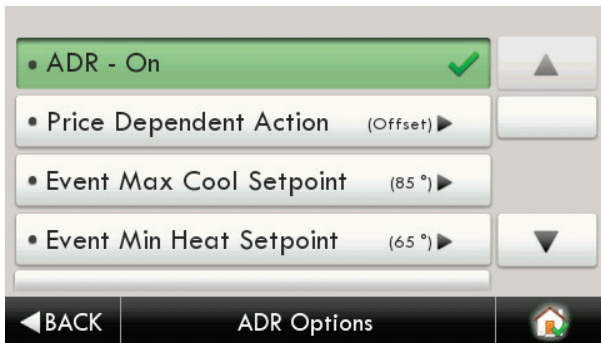

The user may limit the maximum Cooling Setpoint.

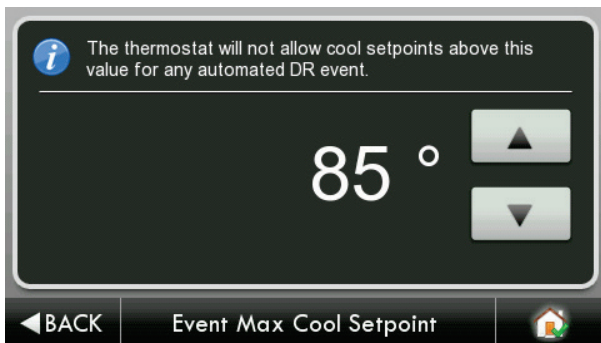

Main Menu Buttons - Settings

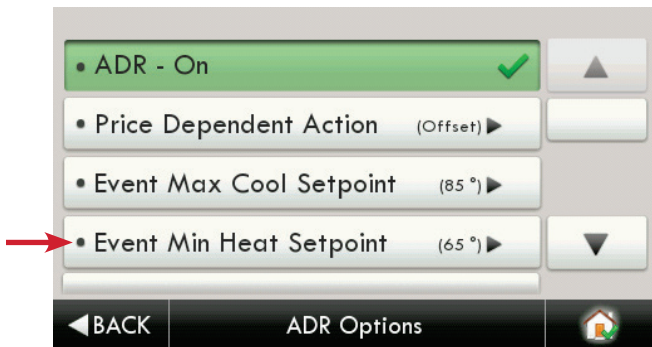

The user may limit the minimum Heating Setpoint.

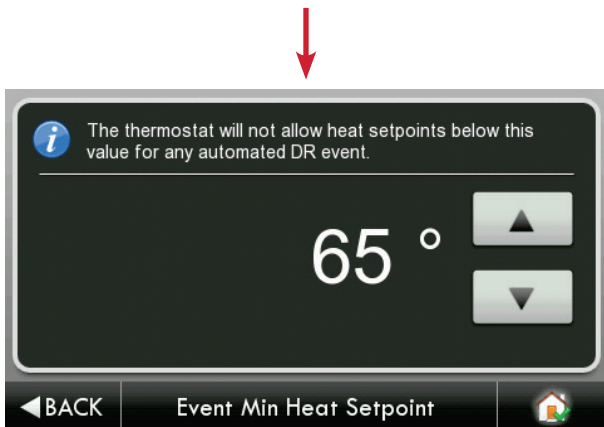

Main Menu Buttons - Settings

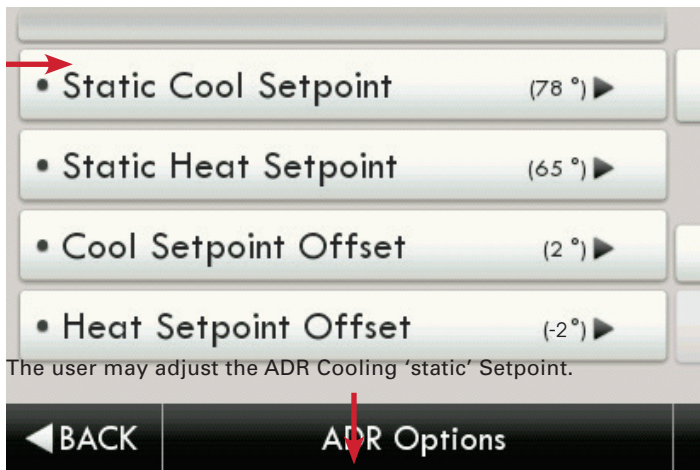

- Static Cool Setpoint (78 °) ▶
- Static Heat Setpoint (65 °) ▶
- Cool Setpoint Offset (2 °) ▶
- Heat Setpoint Offset (-2 °) ▶

◀ BACK ADR Options

The user may adjust the ADR Cooling 'static' Setpoint.

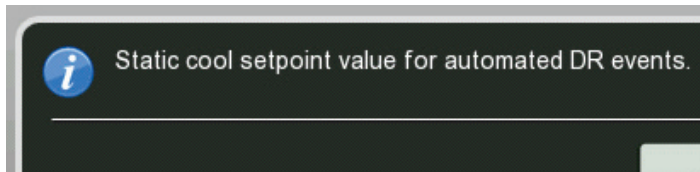

 Static cool setpoint value for automated DR events.

Main Menu Buttons - Settings



The user may adjust the ADR Heating 'static' Setpoint.

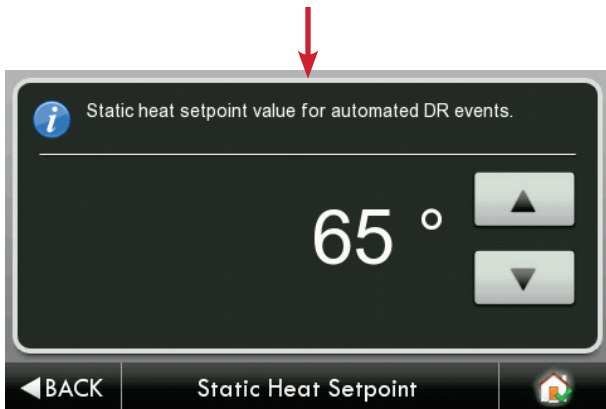

Main Menu Buttons - Settings

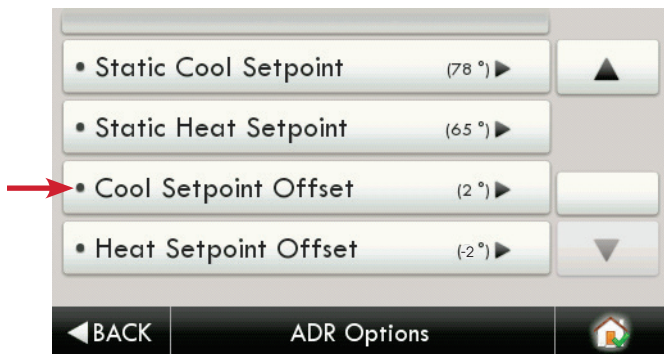

The user may adjust the ADR Cool offset. During an ADR event the cooling setpoint will be adjusted by the amount of degrees configured in this step.

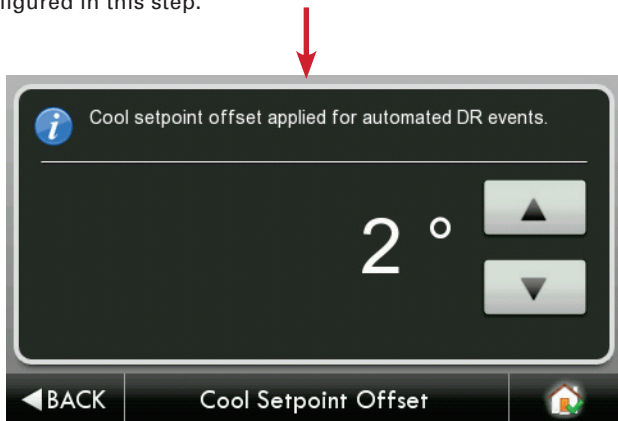

Main Menu Buttons - Settings

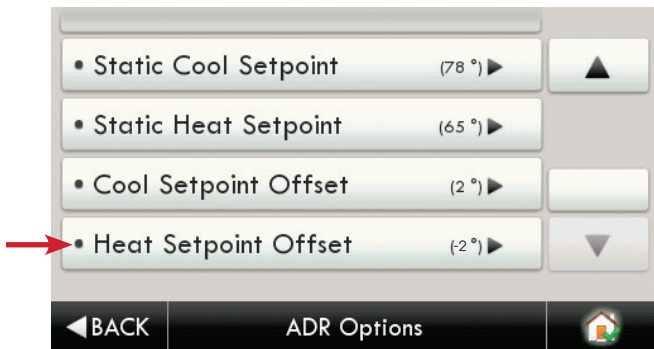

The user may adjust the ADR Heat offset. During an ADR event the heating setpoint will be adjusted by the amount of degrees configured in this step.

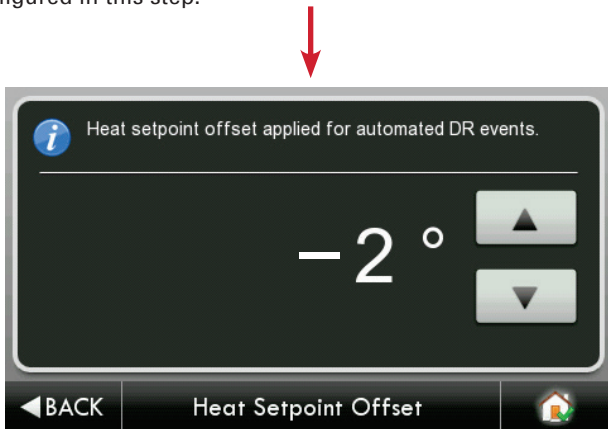

Main Menu Buttons - Settings

When an ADR event is pending, and hasn't started yet, there will be a yellow leaf on the top bar. This will be accompanied by associated text as shown below.

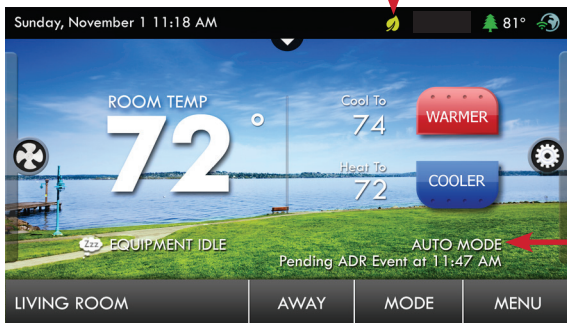

During an ADR event there will be a green leaf on the top bar. This will be accompanied by associated text as shown below.

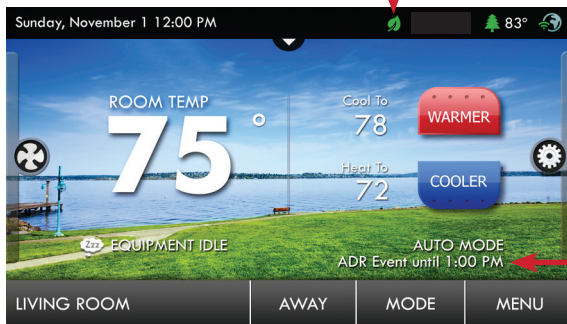

Main Menu Buttons - Settings

If a Warmer or Cooler button is pressed during an active ADR event, then the user is presented with this opt-out screen.

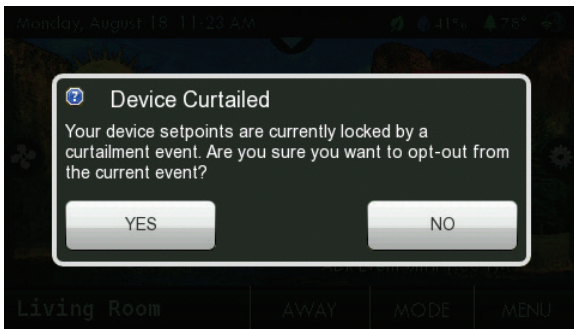

If a pricing triggered ADR event is enabled, there will be a green leaf on the top bar along with the actual cost of energy. This will be accompanied by associated text as shown below

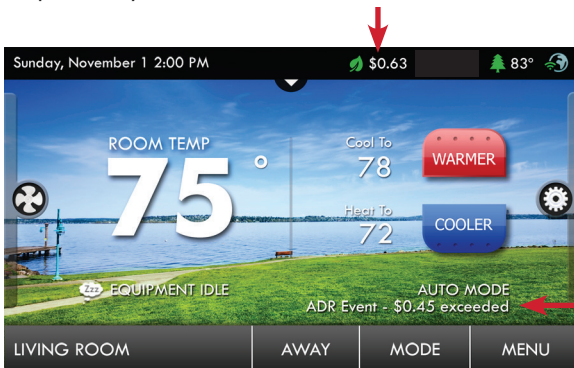

Main Menu Buttons - Settings

• Installation Settings ▶

• Heat & Cool Stages (1h1c) ▶

• Heat & Cool Stages (1h1c) ▶

Up to 2 Stages Cooling and 4 stages Heating.

• Compressor Stages (1h1c) ▶

Up to 2 compressors.

• Aux Heat Stages (1h1c) ▶

0 to 2 stages of Aux Heating.

} Only available when
dip switch is set for
Heat Pump operation.

• Timers & Deadbands ▶

• Cycles Per Hour (6) ▶

At 6 cycles per hour, the HVAC unit will only be allowed to energize once every 10 minutes. The Cycles Per Hour limit may be overridden and reset by pressing the WARMER or COOLER buttons. (2, 3, 4, 5, 6, No Limit)

• Min Heat/Cool Difference (2°) ▶

The minimum gap between Heat and Cool setpoints. (0 - 6 deg. F)

• Compressor Min OFF Time (5m) ▶

None, 3 minute, or 5 minutes.

Main Menu Buttons - Settings

• Installation Settings ▶

(Continued)

• Timers & Deadbands ▶

(Continued)

The Deadband is the number of degrees or minutes that the thermostat waits before it initiates the stages of heating or cooling.

1st Stage Deadband Specifies the minimum temperature difference between the room temperature and the desired setpoint before the first stage of heating or cooling is allowed to turn on. For example, if the heat setpoint is 68° and the 1st Stage deadband is set to 2 degrees, the room temperature will need to drop to **66 degrees** before the heat turns on.

• 1st Stage Deadband ▶

(2°)

(1 - 6 deg. F)

• 2nd Stage Deadband ▶

• 2nd Stage Deadband ▶

(2°)

Number of degrees past 1st stage before 2nd stage turns on. (0 - 10 deg. F)

• 2nd Stage Timer ▶

(2mins)

Number of minutes past 1st stage before 2nd stage turns on. (0 - 60 mins.)
(The 2nd stage deadband must also be met)

• 2nd Stage Turnoff Point (Deadband) ▶

Deadband or Setpoint.

• 3rd Stage Deadband ▶

• 4th Stage Deadband ▶

The 3rd and 4th stage deadband settings have the same adjustable steps as 2nd stage deadband.

Main Menu Buttons - Settings

• Installation Settings ▶

(Continued)

• Free Cooling ▶

Free Cooling requires additional dampers and duct work to be installed. Additionally, the thermostat is wired in a different manner for this feature to function properly. Before enabling this feature, please make sure these steps are completed.

• Free Cooling - DISABLED

• Free Cooling - ENABLED ✓

Turns on Free Cooling.

• Usable Outdoor Temp (65°) ▶

Free Cooling shuts off above this outdoor temperature. (40 - 80 degrees F)

• Mechanical Cooling? - NO

• Mechanical Cooling? - YES ✓

If you don't have a compressor, set Mechanical Cooling to "NO", Y1 will then be used to control the Free Cooling Damper(s) and Y2 will be disabled. If set to "YES", mechanical (compressor) cooling will be controlled by the Y2 terminal. (See page for wiring diagram)

Mechanical air conditioning is turned on with a 2nd stage demand for cooling and the Free Cooling, outdoor air damper is closed.

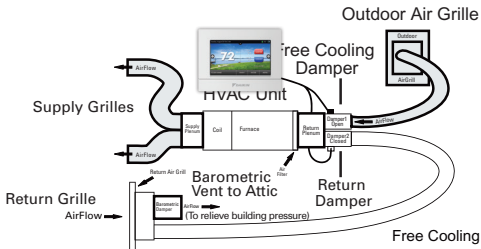

Main Menu Buttons - Settings

• Installation Settings ▶

(Continued)

• Heat Pump Settings ▶

(Only available when dip switch is set for Heat Pump operation.)

• Heat Pump Lockout - DISABLED ▶

• Heat Pump Lockout - ENABLED ✓

Turns on Heat Pump Lockout.

• HP Lockout Outdoor Temp (65°) ▶

Heat Pump will not run below this temp. (20 - 75 deg. F)

• Aux Heat Lockout - DISABLED ▶

• Aux Heat Lockout - ENABLED ✓

Turns on Aux Heat Lockout.

• Aux Heat Lockout Temp (65°) ▶

Aux Heat will not run above this temp. (0 - 75 deg. F) **GAS/EL** or **HP** dip switch must be set for **HP** and **GAS** or **ELEC** dip switch must be set for **ELEC**.

• Dual Fuel Settings ▶

This feature is for heat pump applications only.

This will only appear if the GAS/EL or HP dip switch is set for HP and the GAS or ELEC dip switch is set for Gas.

When Dual Fuel is ON, an outdoor temperature or, if Change With Outdoor is set to OFF a demand for third stage heat will be used to stop running the heat pump and switch to a fossil fuel source of heat. **NOTE:** Once the change to fossil fuel is made, the heat demand must finish with fossil fuel. Additional heat demands within 10 minutes will also use fossil fuel, regardless of outdoor temperature or stage demand.

• **Dual Fuel - ON/OFF**

• **Changeover With Outdoor - ON/OFF**

ON: Uses an outdoor sensor for changeover.

OFF: Uses a third stage heat demand for changeover.

• **Adjust Balance Point**

Choose the temperature for changeover to fossil fuel. (0 - 60 deg. F)

Main Menu Buttons - Settings

• Installation Settings



• AUX Output Settings



Main Menu Buttons - Settings

• Installation Settings ▶ (Continued)

• Fan Off Delay (0s) ▶

Runs the fan for a short time after Cooling or electric strip heat turns off to increase system efficiency. (0 - 120 Secs.)

• Sensor Settings ▶

• Control Sensor (thermostat) ▶

When a remote sensor is connected to the thermostat, the user may choose which sensor source is used to measure room temperature.

- Thermostat sensor only
- Remote Sensor only
- Average remote/thermostat

• Wired Sensor Use (remote) ▶

The wired sensor may be used as follows:

- Outdoor sensor
- Remote Sensor
- Supply Sensor
- Return Sensor

• Calibrate Sensors (0°) ▶

The thermostat and wired sensor may be calibrated -7 to +7 degrees F. The integral humidity sensor may be calibrated -20% to +20% RH

• Test Outputs ▶

The installer or service technician can use this feature to test the functions without any time delays of the thermostat.

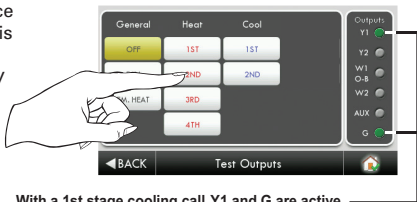

Main Menu Buttons - Settings

• Dealer Information ▶

A Dealer may enter their company contact information for the customer to use when they need service. This will appear when the “Who To Call For Service” button is pressed in the Information Menu.

Use the keyboard to enter your information.

- Dealer Name
- Contact Name
- Dealer Phone
- Dealer Email
- Dealer Website

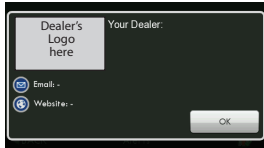

• Upgrade Firmware ▶

Press to upgrade the thermostat firmware. The SD Card must be in the thermostat SD Card reader and contain the valid firmware. If an error message appears, confirm with ColorTouch Assistant that firmware is up to date or simply try reinserting the SD card.

If you are connected to Skyport Wi-Fi and you receive an Alert that new firmware is available, simply press the Upgrade Firmware button to upgrade wirelessly.

Note: Occasionally an update that requires a large amount of data is not possible to do wirelessly. In this case an update using an SD card will be required.

• Delete Custom Images ▶

Press to delete the custom photos you uploaded to the thermostat.

• Calibrate Clock (0 mins) ▶

If needed, the clock may be calibrated up to -10 to +10 minutes per month.

• Factory Defaults ▶

Press to reset the thermostat back to the factory settings.

• Restart Thermostat ▶

If needed, press here to restart the thermostat.

Main Menu Buttons - Wi-Fi

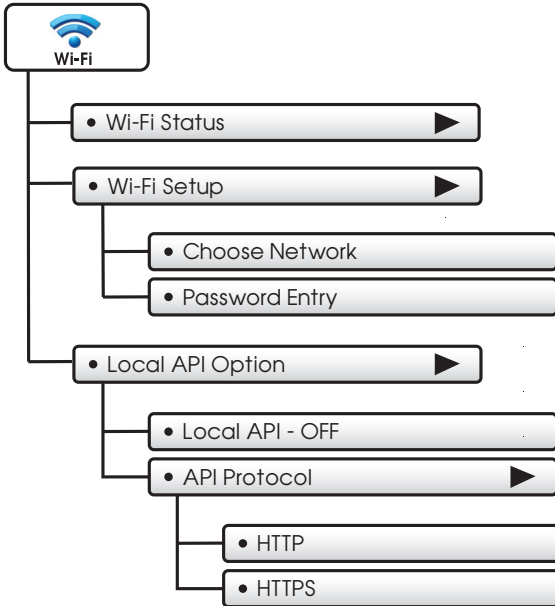

Main Menu Buttons - Wi-Fi



- Wi-Fi Enabled

This option allows the Wi-Fi radio to be turned off or on.

- Wi-Fi Status

It is here that you will find helpful information regarding the connectivity status of your thermostat, including the thermostat's ID.

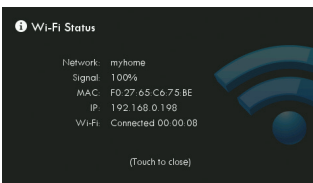

- Wi-Fi Setup

Choose your network from the list and enter the network password.

-  If your network does not appear in the list, hit the refresh button.

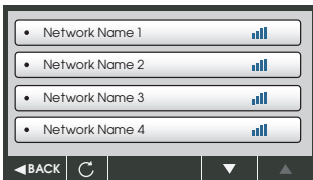

- Local API Option

Turning on the local API allows 3rd party software to interface with your thermostat, such as a home automation system.

Main Menu Buttons - Wi-Fi

This is the default with the local API OFF.

• Local API - OFF

• API Protocol (http) ▶

To turn on the HTTP Local API select **Local API**

• Local API - ON ✓

• API Protocol (http)

Press **BACK** to return to previous screen.

If a Secure API is preferred, then select **API Protocol**

• Local API - OFF

• API Protocol (http) ▶

Upon pressing **API Protocol**, the following screen will appear.

• HTTP ✓

• HTTPS

Then select **HTTPS** and press **BACK**

• HTTP

• HTTPS ✓

Main Menu Buttons - Wi-Fi

Upon pressing **BACK**, the screen will look like this.

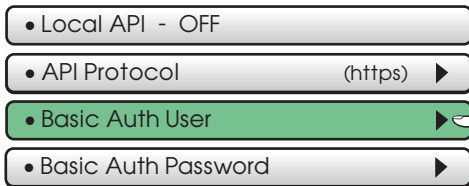

PRESS



Select **Basic Auth User**, and enter the appropriate information on the screen below and press **DONE** to save.

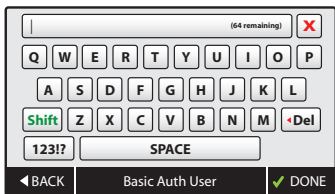

Select **Basic Auth Password** as the next step.

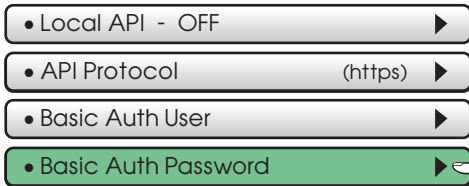

PRESS

Main Menu Buttons - Wi-Fi

• Basic Auth Password ▶

Select **Basic Auth Password** and enter the appropriate information on the screen below and press **DONE** to save.

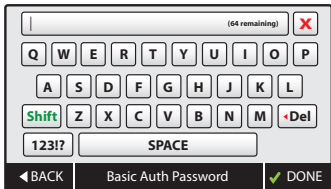

The last step is to turn the **Local API** as shown below.

• Local API - ON ✓

• API Protocol (https)

• Basic Auth User ▶

• Basic Auth Password ▶

Main Menu Buttons - Skyport

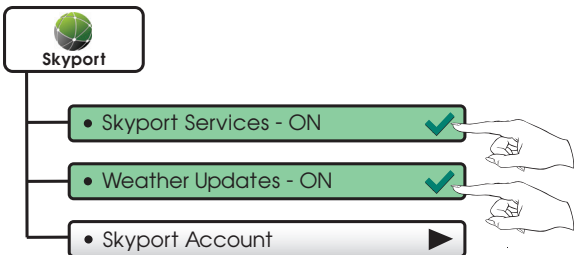

• Skyport Account ▶

Pressing this button will let you know if you are paired with a Skyport account. If not, then you may follow prompt and instructions to create an account and add the thermostat to the account.

Main Menu Buttons - Emergency Heat



The Emergency Heat function is only available if your thermostat is set to control a Heat Pump.

To initiate the Emergency Heat feature, Press the Emergency Heat button. During Emergency Heat operation the thermostat will turn on the fan and auxiliary stages of heat when there is a demand for heat. The 1st stage of heating and all stages of cooling will be unavailable. To exit Emergency Heat, press the Emergency Heat button.

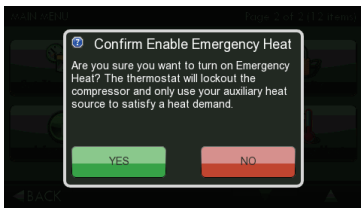

The TouchScreen Assistant

TouchScreen Assistant may be downloaded at no charge at:

www.Daikinthermostats.com/touchscreen/



Every time the user runs the TouchScreen Assistant software, it automatically connects to Daikin's TouchScreen website in the background and updates the software and firmware (the operating system for TouchScreen) at no cost.

The **TouchScreen Assistant** allows you to use your computer to:

- Upload photos for background and slideshow images
- Program a time period schedule
- Configure installation settings
- Upload dealer and service contact information and company logo
- An alternative method to update thermostat firmware

The TouchScreen Assistant

Uploading Photos and Settings to your thermostat

When you are finished adding and editing photos and settings, click on **Save to SD**. When prompted, remove the SD card from the SD card reader on your computer.



Save to SD

*NOTE: A 2GB SD card is recommended.

At the thermostat:

Insert the SD card into the SD Card Slot.

Press

MENU

then



Next, press



SD Card Slot

Press

• SD Card



Then press

• Import Settings from SD Card



Select the items to import into your thermostat then press

NEXT



Your thermostat will automatically save your new photos and settings in its internal memory. When finished, you may remove the SD card. It is not needed for normal thermostat operation.

Installation Instructions

Remove and Replace the old thermostat

To install the thermostat properly, please follow these step by step instructions. If you are unsure about any of these steps, call a qualified technician for assistance.

- Assemble tools: Flat blade screwdriver, wire cutters and wire strippers.

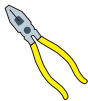

- Make sure your Heater/Air Conditioner is working properly before beginning installation of the thermostat.
- Carefully unpack the thermostat. Save the screws, any brackets, and instructions.
- Turn off the power to the Heating/Air Conditioning system at the main fuse panel. Most residential systems have a separate breaker for disconnecting power to the furnace.
- Remove the cover of the old thermostat. If it does not come off easily, check for screws.
- Loosen the screws holding the thermostat base or subbase to the wall and lift away.
- Disconnect the wires from the old thermostat. Tape the ends of the wires as you disconnect them, and mark them with the letter of the terminal for easy reconnection to the new thermostat. Additionally, we recommend taking a photo with your phone of the connections for future reference.
- Keep the old thermostat for reference purposes, until your new thermostat is functioning properly.

Installation Instructions

Wire Connections

If the terminal designations on your old thermostat do not match those on the new thermostat, **refer to the chart below or the wiring diagrams that follow.**

Wire from the old thermostat terminal marked	Function	Install on the new thermostat connector marked
G or F	Fan	G
Y1, Y	Cooling	Y1
W1, W	Heating	W1/O/B
Rh, R, M, Vr, A	Power	R
C	Common	C
O/B	Rev. Valve	W1/O/B*
W2	2nd Stage Heat	W2
Y2	2nd Stage Cooling	Y2
W3	3rd Stage Heat	W3
OUT -	Outdoor Sensor	SENSOR
OUT +	Outdoor Sensor	SENSOR

* O/B is used if your system is a Heat Pump.

Installation Instructions

Before you go any further, determine what your existing wiring and equipment situation is.

- A. If you have a **Heating only system** without Air Conditioning, the Daikin thermostat will require **3 wires**: R (24Vac), C (24Vac) and W (Heat). Most systems that only have Heating use very simple thermostats that require 2 wires: the R (24Vac) and W (Heat). The Daikin thermostat requires **3 wires** to the thermostat. In this case an Add-a-Wire accessory will not work and it will be necessary to install another wire for the C (24Vac) connection.
- B. If you have a **single stage fossil fuel heater with air conditioning**, the Daikin model will require **5 wires** for independent fan control. They are R (24Vac), C (24Vac), W (Heat), Y (Cooling), and G (Fan). You may connect only 4 wires, as instructed in the “Making 4 Wires Work When 5 Wires Are Required” section on page 74.

If there are only 4 wires present that are connected to the existing thermostat, there are at least 3 options available to connect the Daikin thermostat:

1. Use the 4 wires as instructed in the “Making 4 Wires Work When 5 Wires Are Required” section on page 74, and note that the fan will only operate with a Heating or Cooling demand.
 2. Pull new thermostat wire from the HVAC equipment to the thermostat so that there are at least 5 wires available.
 3. Purchase and install a Daikin Add-A-Wire accessory.
- C. If you have a **multi-stage HVAC system comprised of a fossil fuel heater with air conditioning**, the Daikin thermostat will require the 5 wires mentioned above (R, C, W, Y, G) plus an additional wire for each additional stage of Heating or Cooling. You may reduce the 5 wire requirement to 4 if you give up independent fan control following the instruction in the “Making 4 Wires Work When 5 Wires Are Required” section on page 53, or use the optional Add-A-Wire accessory.

Installation Instructions

- D. If you have a **heat pump without aux heat**, the Daikin model will require 5 wires: R (24Vac), C (24Vac), W1/O/B (Reversing Valve), Y (1st Stage Compressor), and G (Fan).

If you are short 1 wire, there are at least 3 options available to connect the Daikin thermostat:

1. Use the available wires as instructed in the “Making 4 Wires Work When 5 Wires Are Required” section on page 56 and note that the fan will only operate with a Heating or Cooling demand.
2. Pull new thermostat wire from the HVAC equipment to the thermostat so that there are at least 5 wires available.
3. Purchase and install a Daikin Add-A-Wire accessory.

- E. If you have a **heat pump with aux heat**, the Daikin model will require 6 wires: R (24Vac), C (24Vac), W1/O/B (Reversing Valve), Y (1st Stage Compressor), W2 (Aux Heat), and G (Fan).

If you are short 1 wire, there are at least 3 options available to connect the Daikin thermostat:

1. Use the available wires as instructed in the “Making 5 Wires Work When 6 Wires Are Required” section on page 57 and note that the fan will only operate with a Heating or Cooling demand.
2. Pull new thermostat wire from the HVAC equipment to the thermostat so that there are at least 6 wires available.
3. Purchase and install a Daikin Add-A-Wire accessory.

Installation Instructions

Making 4 Wires Work When 5 Wires Are Required

If you would like to install the Daikin thermostat using only 4 wires when 5 are required, follow the directions below. You will need a screwdriver along with a 3" long piece of thermostat wire to use as a jumper:

1. Make sure the power is off.
2. Label and disconnect wires at the thermostat. Please note the color and corresponding wire designator with each color. For example: The R wire is red and the W wire is white and so on. You will need this information handy for the next step at the HVAC equipment.
3. At the HVAC equipment end of the thermostat wires (usually at the furnace), locate the terminals that the wires are attached to.
4. Remove the "G wire" from the terminal marked G.
5. Place the "G wire" on terminal C.
6. Place one end of the 3" long jumper on terminal G.
7. Place the other end of the 3" long jumper on terminal Y. Please note that there will be more than 1 wire on terminal Y.
8. When connecting the wires to the Daikin thermostat, note that the wire that was previously connected to the G terminal of the old thermostat will now be required to be connected to the C terminal on the Daikin thermostat. **All other wires** will be connected such that the connections on **each end of the individual wires match terminal designations**. For example: Connect the yellow wire on the thermostat end to the Y terminal on the thermostat. The yellow wire will be connected to the Y terminal on the HVAC equipment end also.

Installation Instructions

Making 5 Wires Work When 6 Wires Are Required

If you have a system that requires 6 wires, and you would like to install the Daikin thermostat using only 5 wires, follow the directions below. You will need a screwdriver along with a 3" long piece of thermostat wire to use as a jumper:

1. Make sure the power is off.
2. Label and disconnect wires at the thermostat. Please note the color and corresponding wire designator with each color. For example: The R wire is red and the W wire is white and so on. You will need this information handy for the next step at the HVAC equipment.
3. At the HVAC equipment end of the thermostat wires (usually at the furnace), locate the terminals that the wires are attached to.
4. Remove the "G wire" from the terminal marked G.
5. Place the "G wire" on terminal C.
6. Place one end of the 3" long jumper on terminal G.
7. Place the other end of the 3" long jumper on terminal Y. Please note that there will be more than 1 wire on terminal Y.
8. When connecting the wires to the Daikin thermostat, note that the wire that was previously connected to the G terminal of the old thermostat will now be required to be connected to the C terminal on the Daikin thermostat. **All other wires** will be connected such that the connections on **each end of the individual wires match terminal designations**. For example: Connect the yellow wire on the thermostat end to the Y terminal on the thermostat. The yellow wire will be connected to the Y terminal on the HVAC equipment end also.

Installation Instructions

The TouchScreen Backplate

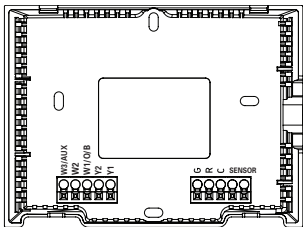

NOTE:

The backplate does not fully cover a full size vertical junction box. The TSTATGTAC-WP Daikin Wallplate or a single-gang, horizontally mounted junction box would be needed for that type of installation

To remove the thermostat backplate:

Using the Finger Pull Areas, pull the front housing away from the backplate.



Look for these tabs to locate the pull areas

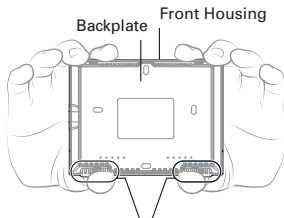

Pull out with thumbs in these areas

W3	3rd stage heat circuit
W2	2nd stage heat circuit
W1/O/B	1st stage heat circuit
Y2	2nd stage compressor relay
Y1	1st stage compressor relay
G	fan relay
R	24 VAC return
C	24 VAC common
SENSOR	remote/outdoor/supply/return sensor connections

IMPORTANT: This thermostat requires both R (24 VAC Return) and C (24 VAC Common) be connected to the backplate terminals.

Installation Instructions

Explanation of Thermostat Dip Switches

Dip switches are located on the back of the thermostat

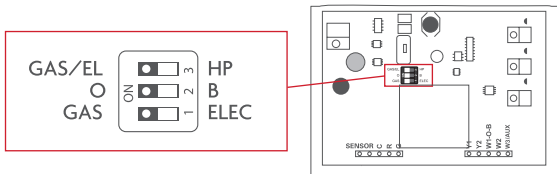

GAS/EL HP



OR

GAS/EL HP



This dip switch configures the thermostat to control a conventional gas/electric system or a heat pump. If your system is anything other than a heat pump, leave this switch set for GAS/EL.*

*For some commercial heat pumps, this switch may need to be set for GAS/EL. Consult the commercial heat pump literature.

O B



OR



When the GAS/EL or HP dip switch is configured for HP, this dip switch (O or B) must be set to control the appropriate reversing valve. If O is chosen, the W1/O/B terminal will energize in cooling. If B is chosen, the W1/O/B terminal will energize in heating.

GAS/ELEC



OR

GAS/ELEC



1. When **GAS/EL or HP** is set for **GAS/EL**:

This switch (GAS or ELEC) controls how the thermostat will control the Fan (G) terminal in heating mode. When **GAS** is chosen, the thermostat **will not** energize the Fan (G) terminal in heating. When **ELEC** is chosen the thermostat **will** energize the fan in heating.

2. When **GAS/EL or HP** is set for **HP**:

This switch (GAS or ELEC) defines the Aux Heat type. When **GAS** is chosen, the auxiliary heat will not be allowed to run during heat pump operation. When using a Dual Fuel system, set this switch for **GAS**. When **ELEC** is chosen, up to two stages of auxiliary strip heat will be allowed to run.

Installation Instructions

Sample Wiring Diagrams with Dip Switch Positions

Conventional Heating and Cooling Systems

2 Wire, Heat Only

Residential & Commercial 1 Stage Heating with no Fan.

The thermostat will not work with 2 wires. Either pull new wire or purchase a model TSTATGAC0410 two-wire kit

GAS/EL		HP
O		B
GAS		ELEC

3 Wire, Heat Only

Residential & Commercial 1 Stage Heating with no Fan.

R	24VAC Power
C	24VAC Common
W1/O/B	1st Stage Heat

GAS/EL		HP
O		B
GAS		ELEC

4 Wire, Cool Only

Residential & Commercial 1 Stage Cooling.

R	24VAC Power
C	24VAC Common
Y1	1st Stage Cool
G	Fan

GAS/EL		HP
O		B
GAS		ELEC

5 Wire, 1 Stage Cooling, 1 Stage Heat

Residential & Commercial 1 Stage Cooling, with 1 stage Gas Heat.

R	24VAC Power
C	24VAC Common
W1/O/B	1st Stage Heat
Y1	1st Stage Cool
G	Fan

GAS/EL		HP
O		B
GAS		ELEC

5 Wire, 1 Stage Cooling, 1 Stage Heat

Residential & Commercial 1 Stage Cooling, with 1 stage Electric Heat.

R	24VAC Power
C	24VAC Common
W1/O/B	1st Stage Heat
Y1	1st Stage Cool
G	Fan

GAS/EL		HP
O		B
GAS		ELEC

8 Wire, 2 Stage Cooling, 3 Stage Heat

Residential & Commercial 2 Stage Cooling, with 3 stage Gas Heat.

R	24VAC Power
C	24VAC Common
W1/O/B	1st Stage Heat
W2	2nd Stage Heat
W3/AUX	3rd Stage Heat
Y1	1st Stage Cool
Y2	2nd Stage Cool
G	Fan

GAS/EL		HP
O		B
GAS		ELEC

Installation Instructions

Sample Wiring Diagrams with Dip Switch Positions

Heat Pump Systems

5 Wire, 1 Stage Cooling, 1 Stage Heat

Residential & Commercial Heat Pump with
'O' Reversing Valve

R	24VAC Power
C	24VAC Common
W1/O/B	Reversing Valve
Y1	1st Stage Compressor (Cool or Heat)
G	Fan

GAS/EL		HP
O		B
GAS		ELEC

6 Wire, 1 Stage Cooling, 2 Stage Heat

Residential & Commercial Heat Pump with
'O' Reversing Valve

R	24VAC Power
C	24VAC Common
W1/O/B	Reversing Valve
Y1	1st Stage Compressor (Cool or Heat)
W2	Aux Heat
G	Fan

GAS/EL		HP
O		B
GAS		ELEC

7 Wire, 2 Stage Cooling, 3 Stage Heat

Residential & Commercial Heat Pump with
'O' Reversing Valve.

R	24VAC Power
C	24VAC Common
W1/O/B	Reversing Valve
W2	3rd Stage Heat
Y1	1st Stage Compressor (Cool or Heat)
Y2	2nd Stage Compressor (Cool or Heat)
G	Fan

GAS/EL		HP
O		B
GAS		ELEC

(Number of Compressor Stages set to 2)

8 Wire, 2 Stage Cooling, 4 Stage Heat

Residential & Commercial Heat Pump with
'O' Reversing Valve.

R	24VAC Power
C	24VAC Common
W1/O/B	Reversing Valve
W2	3rd Stage Heat
W3	4th Stage Heat
Y1	1st Stage Compressor (Cool or Heat)
Y2	2nd Stage Compressor (Cool or Heat)
G	Fan

GAS/EL		HP
O		B
GAS		ELEC

(Number of Compressor Stages set to 2)

Installation Instructions

Sample Wiring Diagrams with Dip Switch Positions

Heat Pump Systems with Dual Fuel

7 Wire, 2 Stage Cooling, 3 Stage Heat
Residential & Commercial Heat Pump with
'O' Reversing Valve and Fossil Fuel furnace.

R	24VAC Power
C	24VAC Common
W1/O/B	Reversing Valve
W2	3rd Stage Heat (connected to furnace)
Y1	1st Stage Compressor (Cool or Heat)
Y2	2nd Stage Compressor (Cool or Heat)
G	Fan

GAS/EL	<input type="checkbox"/>	1	2	3	HP
O	<input type="checkbox"/>	1	2	3	B
GAS	<input type="checkbox"/>	1	2	3	ELEC

Number of Compressor Stages
set to 2
(see *Compressor Stages*, pg. 33)

Dual Fuel set to On
(see *Dual Fuel Settings*, pg. 36)

Free Cooling

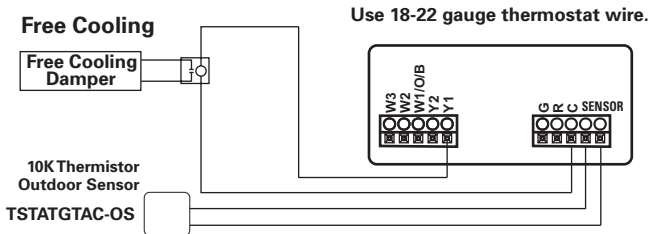

Free Cooling utilizes the Y1 terminal for the operation of 1st stage cooling. If mechanical (compressor) cooling is also present, the mechanical cooling is connected to the Y2 terminal in this instance.

Free Cooling may be used with a Gas/Electric or Heat Pump system.

Temperature Sensor: TSTATGTAC-OS Temperature Sensor 10K ohm sensor at 77F/25C. Negative Temperature Coefficient.

Troubleshooting

- **SYMPTOM:** The thermostat touchscreen buttons are not responsive.
CAUSE: The touchscreen is out of calibration.
REMEDY: Remove the thermostat from the backplate. Push the thermostat back onto the backplate, while keeping your finger pressed firmly against the center of the touchscreen, until the Calibration screen appears. Re-calibrate the touchscreen. See Touch Calibration section of full user's manual (page 19).
- **SYMPTOM:** The display is blank.
CAUSE: Lack of proper power.
REMEDY: Make sure the power is on to the HVAC and that you have 24vac between **R & C**.
- **SYMPTOM:** The air conditioning does not attempt to turn on.
CAUSE: The cooling setpoint is set too high.
REMEDY: Lower the cooling setpoint or lower the cooling set-point limit. See Setpoint Limits (page 28).
- **SYMPTOM:** The heating does not attempt to turn on.
CAUSE: The heating setpoint is set too low.
REMEDY: Raise the heating setpoint or raise the heating set-point limit. See Setpoint Limits (page 28).
- **SYMPTOM:** When controlling a residential heat pump, and asking for cooling, the heat comes on.
CAUSE: The thermostat reversing valve dip switch is set for **"B"**.
REMEDY: Set the reversing valve jumper for **"O"**.
- **SYMPTOM:** When calling for cooling, both the heat and cool come on.
CAUSE: The thermostat equipment dip switch is configured for **"HP"** and the HVAC unit is a Gas/Electric.
REMEDY: Set the equipment dip switch for **"Gas"**.
- **SYMPTOM:** Air handler control board fuse blows when thermostat is attached to backplate with power on, but does not blow until the thermostat is placed onto the backplate.
CAUSE: The Outdoor sensor and/or sensor wiring is shorted.
REMEDY: Check/replace Outdoor sensor and/or sensor wiring.

Index

A

Accessories, 34, 57, 69, 74, 76, 78

Active Brightness, 21

Alerts, 19

- view current, 19
- reset, 19
- set/edit reminders, 19
- See also Runtime

API, 60, 63

Auto

- adjust temperature, 4
- changeover, 4
- fan, 4
- mode, 4

Automated Demand Response, 38

Auto Screenlock, 29

Aux Heat Lockout, 55

Available Modes, 36

B

B Reversing Valve, 69

Backlight, 21

Backplate, 74

Beep, 24

Buttons,

- Back, 1
- Cooler, 1, 4
- Fan, 1, 4

- Home, 1
- Mode, 1, 4
- Menu, 1, 6
- Warmer, 1, 4

C

C, 69

Calibration, 22, 79

Celsius, 36

Choose Network, 60

Cleaning, 22

Clock

- Display 1
- Setting, 6

Compressor Lockout, 52

Cool

- 1st stage deadband, see Deadband
- 2nd stage deadband, see Deadband
- Minutes of runtime, 31, 52

Custom Wallpaper, 17, 24

Cycles Per Hour, 52

D

Daylight Savings, 7

Deadband

- 1st stage, 53
- 2nd stage, 53

3rd stage, 53

4th stage, 53

Dealer Information, 31, 58

Delay

- Fan-off, see Fan
- Time between stages, see Time Delay

Differential

- Heat and cool, 52

Dimmer, 21

Dip Switches, 75

- ELEC, 75
- electric heat, 75
- GAS/EL, 75
- GAS, 75
- HP, 75
- heat pump, 75
- O, 75
- B, 75

Disabled Buttons

- see Security

Display, 21, 22

Dual Fuel

- changeover balance point, 78
- control two heat sources, 78
- operation, 78
- outdoor sensor, 76, 78

E

Electric Heating

- Aux heat, 55
- Dip switch setting, 75
- Lockout, 55

Index

Emergency Heat, 67

Energy Watch

Cool, 29

Heat, 29

Aux heat, 29



Factory Defaults

resetting, 58

Fahrenheit, 36

Fan

button function,
see Buttons

off time delay, 57

on during heat,

see Electric Heat

runtime, 31

2nd stage heat, see

Emergency Heat

Free Cooling, 54, 78



Gas/Electric Furnace

dip switch, 75

General Setup, 36



Heat

1st stage

deadband, see

Deadband

emergency heat, 65

minutes of

runtime, 31

2nd stage deadband,

see Deadband

electric strip heat,

see Aux Heat

minutes of

runtime, 31

3rd stage deadband,

see Deadband

4th stage deadband,

see Deadband

timer, 53

turnoff point, 53

electric/heat pump, 55

mode, 4

program, see Schedule

runtime, see Runtime

setpoint, 4

Heat/Cool Indicator, 24

Heat Pump

aux heat, 52, 55

aux heat lockout, 55

emergency heat, 65

heat pump lockout, 55

dip switch setting,

75, 77

multi-stage, 52, 55



Idle Brightness, 21

Information, 31

Installation Settings, 52

Installation, 68



Keypad, 29, 36



Language, 37

Lock

see Security

Logo, 19

Index

M

- Main Menu, 1**
- Maintenance, 22**
- Manual**
 - changeover, 37
 - cool, 4
 - heat, 4
- Mode, 1, 4**
- Morning Warm-up,**
see Smart Recovery
- MultiStage Operation, 70**

N

- Network Password,**
60, 62
- Night Dimmer, 21**
- Non-Programmable
Thermostat, iii**

O

- O Reversing Valve, 75**
- Off Mode, 4**

Outdoor

- calibrate, 57
- high and low temp, 1
- sensor, 76, 78
- viewing temp,

P

- Passcode, 29, 60, 62**
- Photos, 58, 66**
- Preferences, 24**
- Program**
 - daily schedule, 12

R

- Reset**
 - alert messages, 19
 - thermostat settings,
see Factory Defaults
 - runtime,
 - fan/filter, 19
 - UV light, 19
- Reversing Valve, 75, 77**
- Runtime**
 - resetting, see Reset
 - service filter, 19
 - UV light, 19
 - viewing, 19, 31

S

- Schedule**
 - turn on/off, 12-13
 - view, 12-13
 - edit, 12-13
- Screen Cleaning, 22**
- Screensaver**
 - turn on/off, 17
 - setup, 17
 - preview, 17
- SD Card, 36**
- 2nd stage turn off**
 - temperature, 53
- Secure API, 61**
- Security, 29**
- Service**
 - alerts, 19
 - information, 30
- Set Clock,** see Clock
- Setpoint**
 - balance point, 55
 - cool, 4
 - heat, 4
 - limits, 27
 - vacation, 27
- Settings, 31-38**
- Simple Thermostat, 37**
- Skyport Service, 64**
- Smart Fan, 15**
- Smart Recovery, 37**
- Sound Options, 24**
- Stages, 52**

Index

T

Terminals,

see Backplate

Test Outputs, 57

Thermostat Sensor

calibrate, 57

Three Stage Heat, 52

Time, see Clock

Timers, 52

Time Delay,

compressor lockout, 52

cycles per hour, 52

1st stage to 2nd stage, 53

2nd stage to 3rd stage, 53

3rd stage to 4th stage, 53

Time schedule,

see Schedule

Touch Calibration, 79

TouchScreen Assistant, 66

U

Upgrade Firmware, 58

User Interface Themes, 24

UV Light,

resetting, 19

runtime, see Runtime

setting, see Runtime

V

Vacation

modes, 26

schedule, 26

setpoints, 26

W

W1, 72, 73, 76

W2, 72, 73, 76

W3, 72, 73, 76

Wallpaper, 17, 24

Warranty, 84

Wiring, 71

dual fuel, 78

free cooling, 54, 78

gas/electric, 75

heat pump, 77

Y

Y1, 50

Y2, 50

Limited Warranty

Thermostat Models: D1100, D1152, D2100, D2152, D2270, D2270C, D2111, D4272, D4273, D4271C, D4272C, D4272RT, D4273RT, D4272CT, D4273CT

Who Is Providing The Warranty?

This warranty is provided to you by Goodman Manufacturing Company, L.P. ("Goodman"), which warrants all parts of this thermostat ("control"), as described below.

To What Type Of Installations Does This Warranty Apply?

This warranty applies to controls installed in owner-occupied residences.

What Units Does This Warranty Not Cover?

This warranty does not apply to:

- Controls that are ordered over the Internet, by telephone, or by other electronic means unless the unit is installed by a dealer adhering to all applicable federal, state, and local codes, policies, and licensing requirements.
- Controls that are installed outside the United States, its territories, or Canada.
- Controls that are installed in buildings other than owner-occupied residences, such as non-residential buildings or residences not occupied by the owner.

What Problems Does This Warranty Cover?

This warranty covers defects in materials and workmanship that appear under normal use and maintenance.

Other Warranties

This warranty is in lieu of all other express warranties. ANY IMPLIED WARRANTIES BY GOODMAN, INCLUDING BUT NOT LIMITED TO WARRANTIES OF MERCHANTABILITY AND FITNESS FOR PARTICULAR PURPOSE, ARE LIMITED TO THE DURATION OF THIS WARRANTY. NO AFFILIATE OF GOODMAN GIVES ANY EXPRESS OR IMPLIED WARRANTY, INCLUDING BUT NOT LIMITED TO WARRANTIES OF MERCHANTABILITY AND FITNESS FOR PARTICULAR PURPOSE, ON THIS UNIT. Some states and provinces do not allow the exclusion of express warranties and/or limitations on how long an implied warranty lasts, so the above exclusion and/or limitation may not apply to you.

For further information about this warranty contact Consumer Affairs at (877) 254-4729 or by mail to 19001 Kermier Rd, Waller, Texas 77484

What Problems Does This Warranty Not Cover?

Goodman is not responsible for:

- Damage or repairs required as a consequence of faulty installation or application. • Damage as a result of floods, fires, winds, lightning, accidents, corrosive atmosphere, or other conditions beyond Goodman's control.
- Damage or the need for repairs arising from the use of components or accessories not compatible with this control.
- Normal maintenance as described in the installation and operating manual.
- Parts or accessories not supplied or designated by the manufacturer.
- Damage or the need for repairs resulting from any improper use, maintenance, operation, or servicing.
- Damage or failure of the control due to interruption in electrical service or inadequate electrical service.
- Any damage caused by frozen or broken water pipes in the event of equipment failure.
- Changes in the appearance of the control that do not affect its performance.
- Replacement of fuses and replacement or resetting of circuit breakers.

When Does Warranty Coverage Begin?

Warranty coverage begins on the "installation date." The installation date is one of two dates depending on the circumstances of purchase:

- (1) For controls installed in a newly constructed residence, the installation date is the date the owner purchases the residence from the builder.
- (2) For controls installed in existing residences, the installation date is the date that the control is originally installed.
- (3) For products on which a manufacture date is indicated, if the date the owner purchases the residence from the builder or the date the product is originally installed cannot be verified, the installation date is three months after the manufacture date.

(4) For products on which a manufacture date is not indicated, if the date the owner purchases the residence from the builder or the date the product is originally installed cannot be verified, the installation date is the date the condensing unit to which the product is paired was originally installed.

How Long Does Warranty Coverage Last?

The warranty lasts for a period up to 1 YEAR.

The warranty period does not continue after the control is removed from the location where it was originally installed. The replacement of a part under this warranty does not extend the warranty period. In other words, Goodman warrants a replacement control only for the period remaining in the applicable warranty that commenced on the installation date.

What Will Goodman Do To Correct Problems?

Goodman will furnish a replacement control, without charge for the control only, to replace any control that is found to be defective due to workmanship or materials under normal use and maintenance. Furnishing of the replacement control is Goodman's only responsibility under this warranty and the furnishing of the replacement control is the owner's only remedy.

THE OWNER AGREES THAT THESE REMEDIES ARE THE OWNER'S EXCLUSIVE REMEDIES FOR BREACH OF ALL WARRANTIES, EXPRESS OR IMPLIED.

What Won't Goodman Do To Correct Problems?

Goodman will not pay for:

- Labor, freight, or any other cost associated with the service, repair, or operation of the control.
- Electricity or fuel costs, or increases in electricity or fuel costs, for any reason, including additional or unusual use of supplemental electric heat.
- Lodging or transportation charges.

WHETHER ANY CLAIM IS BASED ON NEGLIGENCE OR OTHER TORT, BREACH OF WARRANTY OR OTHER BREACH OF CONTRACT, OR ANY OTHER THEORY, NEITHER GOODMAN NOR ANY OF ITS AFFILIATES SHALL IN ANY EVENT BE LIABLE FOR INCIDENTAL OR CONSEQUENTIAL DAMAGES, INCLUDING BUT NOT LIMITED TO LOST PROFITS, LOSS OF USE OF A CONTROL, EXTRA UTILITY EXPENSES, OR DAMAGES TO PROPERTY.

Some states and provinces do not allow the exclusion or limitation of incidental or consequential damages, so the above exclusion may not apply to you.

How Can The Owner Receive Warranty Service?

If there is a problem with the control, contact a licensed contractor.

To receive a replacement control, a licensed contractor must bring the defective control to a Goodman heating and air conditioning products distributor.

For more information about the warranty, contact Consumer Affairs at 877-254-4729 or write to Consumer Affairs, 19001 Kermier Rd, Waller, TX 77484.

This warranty gives you specific legal rights, and you may also have other rights that vary from state to state or province to province.

Quebec Residents

The arbitration provisions of this warranty shall not apply to residents of Quebec.

Non-Owner Occupied Warranty

Products installed in non-residential buildings or in residences not occupied by the owner are warranted for a period of 1 YEAR. **THIS WARRANTY IS PROVIDED IN LIEU OF ANY OTHER WARRANTIES, WHETHER BY GOODMAN OR ANY OF ITS AFFILIATES, EXPRESS OR IMPLIED, INCLUDING ANY IMPLIED WARRANTY OF MERCHANTABILITY OR FITNESS FOR A PARTICULAR PURPOSE.** Subject to the additional limitations set forth in this paragraph, all other provisions of the Limited Warranty apply to products installed in non-residential buildings or in residences not occupied by the owner.

Where Can Any Legal Remedies Be Pursued?

ARBITRATION CLAUSE. IMPORTANT. PLEASE REVIEW THIS ARBITRATION CLAUSE. IT AFFECTS YOUR LEGAL RIGHTS.

1. Parties: This arbitration clause affects your rights against Goodman and any of its affiliates or employees or agents, successors, or assigns, all of whom together are referred to below as "we" or "us" for ease of reference.
2. **ARBITRATION REQUIREMENT: EXCEPT AS STATED BELOW, ANY DISPUTE BETWEEN YOU AND ANY OF US SHALL BE DECIDED BY NEUTRAL, BINDING ARBITRATION RATHER THAN IN COURT OR BY JURY TRIAL.** "Dispute" will be given the broadest possible meaning allowable by law. It includes any dispute, claim, or controversy arising from or relating to your purchase of this control, any warranty upon the unit, or the unit's condition. It also includes determination of the scope or applicability of this Arbitration Clause. The arbitration requirement applies to claims in contract and tort, pursuant to statute, or otherwise.
3. **CLASS-ARBITRATION WAIVER: ARBITRATION IS HANDLED ON AN INDIVIDUAL BASIS. IF A DISPUTE IS ARBITRATED, YOU AND WE EXPRESSLY WAIVE ANY RIGHT TO PARTICIPATE AS A CLASS REPRESENTATIVE OR CLASS MEMBER ON ANY CLASS CLAIM YOU MAY HAVE AGAINST US OR WE AGAINST YOU, OR AS A PRIVATE ATTORNEY GENERAL OR IN ANY OTHER REPRESENTATIVE CAPACITY. YOU AND WE ALSO WAIVE ANY RIGHT TO CLASS ARBITRATION OR ANY CONSOLIDATION OF INDIVIDUAL ARBITRATIONS.**

4. **Discovery and Other Rights:** Discovery and rights to appeal in arbitration are generally more limited than in a lawsuit. This applies to both you and us. Other rights that you or we would have in court may not be available in arbitration. Please read this Arbitration Clause and consult the rules of the arbitration organizations listed below for more information.
5. **SMALL CLAIMS COURT OPTION: YOU MAY CHOOSE TO LITIGATE ANY DISPUTE BETWEEN YOU AND ANY OF US IN SMALL CLAIMS COURT, RATHER THAN IN ARBITRATION, IF THE DISPUTE MEETS ALL REQUIREMENTS TO BE HEARD IN SMALL CLAIMS COURT.**
6. **Governing Law:** For residents of the United States, the procedures and effect of the arbitration will be governed by the Federal Arbitration Act (9 U.S.C. § 1 et seq.) rather than by state law concerning arbitration. For residents of Canada, the procedures and effect of the arbitration will be governed by the applicable arbitration law of the province in which you purchased your control. The law governing your substantive warranty rights and other claims will be the law of the state or province in which you purchased your control. Any court having jurisdiction may enter judgment on the arbitration award.
7. **Rules of the Arbitration:** If the amount in controversy is less than \$250,000, the arbitration will be decided by a single arbitrator. If the amount in controversy is greater than or equal to \$250,000, the arbitration will be decided by a panel of three arbitrators. The arbitrator(s) will be chosen pursuant to the rules of the administering arbitration organization. United States residents may choose the American Arbitration Association (1633 Broadway, 10th Floor, New York, NY 10019, www.adr.org), JAMS (1920 Main Street, Ste. 300, Irvine, CA 92614, www.jamsadr.com), or, subject to our approval, any other arbitration organization. In addition, Canadian residents may choose the ADR Institute of Canada (234 Eglinton Ave. East, Suite 405, Toronto, Ontario, M4P 1K5, www.amic.org). These organizations' rules can be obtained by contacting the organization or visiting its website. If the chosen arbitration organization's rules conflict with this Arbitration Clause, the provisions of this Arbitration Clause control. The award of the arbitrator(s) shall be final and binding on all parties.
8. **Location of the Arbitration Hearing:** Unless applicable law provides otherwise, the arbitration hearing for United States residents will be conducted in the federal judicial district in which you reside or, for Canadian residents, in the province in which you reside.
9. **Costs of the Arbitration:** Each party is responsible for its own attorney, expert, and other fees unless applicable law requires otherwise. Goodman will pay your share of the fees charged by the arbitration organization and arbitrator(s) beyond the first \$200. Where permissible by law, you may be required to reimburse Goodman for the fees of the arbitration organization and arbitrator(s) in whole or in part by decision of the arbitrator(s) at the discretion of the arbitrator(s).
10. **Survival and Enforceability of this Arbitration Clause:** This Arbitration Clause shall survive the expiration or termination, or any transfer, of the warranty on your control. If any part of this Arbitration Clause, except waivers of class-action rights, is found to be unenforceable for any reason, the remainder of this clause and the warranty shall remain enforceable. If, in a case in which class-action allegations have been made, the waiver of class-action rights under this warranty is found to be unenforceable with respect to any part of the dispute, the parts of the dispute as to which the waiver of class-action rights have been found unenforceable will be severed and will proceed in court without reference or application of this Arbitration Clause. Any remaining parts will proceed in arbitration.



Patents Issued & Pending

P/N 88-1144 Rev. 3 01/22

